

# MAINTENANCE MANUAL

## P2200i

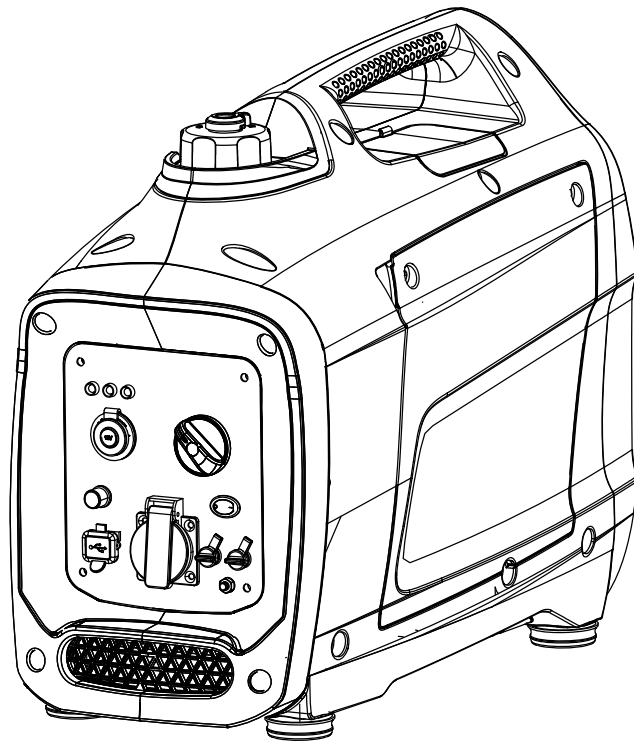

# SAFETY PRECAUTIONS

---

Thoroughly read this **MANUAL** before operating the generator set. Safe operation and top performance can only be attained when equipment is operated and maintained properly.

The following symbols, found throughout this manual, alert you to potentially dangerous conditions to operators, service personnel and equipment.

**⚠ DANGER** *This symbol alerts you to an immediate hazard that will result in severe personal injury or death.*

**⚠ WARNING** *This symbol alerts you to a hazard or unsafe practice that can result in severe personal injury or death.*

**⚠ CAUTION** *This symbol alerts you to a hazard or unsafe practice that can result in personal injury or damage to equipment or property.*

Electricity, fuel, exhaust, moving parts and batteries present hazards against which precautions must be taken to prevent severe personal injury or death.

## Exhaust Gas Is Deadly

- Operate the generator set outdoors only. Stay away from the exhaust outlet.
- Make sure generator set exhaust will not enter windows, doors, vents or air intakes of adjacent buildings, vehicles or boats.
- NEVER USE THE GENERATOR SET INSIDE a home, garage, crawl space, barn, shed, cabin, boat, boat house, RV or tent, or in a confined outdoor space such as an alley, ditch, parking garage or courtyard, or in any other space where exhaust can accumulate. Note that HAZARDOUS CARBON MONOXIDE LEVELS FROM ENGINE EXHAUST CAN ACCUMULATE INDOORS EVEN WHEN ALL WINDOWS AND DOORS ARE OPEN AND FANS ARE RUNNING.

## Gasoline is Flammable / Explosive

- Refuel the generator set outdoors only.

- Static electric sparks caused by fuel flowing through a service station's pump nozzle can ignite gasoline. Never fuel the generator set with a service station's pump nozzle. Instead, fill a safety tank sitting on the ground and then slowly transfer fuel into the generator set from the safety tank.
- DO NOT fill fuel tanks while the engine is running. A hot engine can ignite the fuel.
- To prevent fire due to fuel leakage, always close the fuel valve and let the generator set cool before transporting it or storing it in a confined space.
- DO NOT SMOKE OR ALLOW AN OPEN FLAME near the generator set. Keep flames, sparks, electrical switches, pilot torques, electrical arcs, arc-producing equipment and all other sources of ignition well away generator set.

## Generator Voltage is Deadly

- DO NOT CONNECT THE GENERATOR SET DIRECTLY TO ANY BUILDING ELECTRICAL SYSTEM. Back-feed could cause electrocution of utility line workers and damage to equipment. An approved switching device must be used to prevent interconnections. A trained and experienced electrician must make electrical connections when the generator set is used for emergency power.
- Make sure clothing, shoes and skin are dry when operating electrical equipment.
- Never operate the generator set in rain or snow or when it is sitting on wet ground.

## Moving Parts Can Cause Severe Personal Injury or Death

- Before performing any maintenance on the generator set, disconnect the spark plug wire.
- Always keep hands away from moving parts.
- Do not wear loose clothing or jewelry while servicing the generator set. Loose clothing and jewelry can be caught in moving parts. Jewelry can short out electrical contacts, causing sparks, flame and electrical shock.

# SAFETY PRECAUTIONS

---

- Make sure that fasteners and clamps on the generator set are tight. Keep guards in position over fans, rotors, etc.

## Battery Gases Are Explosive

- Wear safety glasses when servicing batteries.
- Do not smoke.
- To reduce arcing when disconnecting or reconnecting battery cables, always disconnect the negative (–) cable of the battery first and reconnect it last.

## General Precautions

- Keep children away from the generator set.
- Wear hearing protection when near an running generator set.
- Keep a multi-class (ABC) fire extinguisher readily at hand. Class A fires involve ordinary combustible materials such as wood and cloth. Class B fires involve combustible and explosive liquids and gaseous fuels. Class C fires involve live electrical equipment. (ref. NFPA No. 10).

- Benzene and lead may be found in gasoline and have been identified by some states and federal agencies as causing cancer or reproductive toxicity. Do not ingest, inhale or contact gasoline.
- Used engine oil has been identified by some states and federal agencies as causing cancer or reproductive toxicity. Do not ingest, inhale or contact used engine oil or its vapors.
- Keep the generator set clean and dry at all times. Excess grease and oil can catch fire and/or accumulate dirt, which can cause overheating.
- Do not store anything on the generator set, such as oil cans, oily rags, chains or wooden blocks. A fire could result or operation could be adversely affected
- Do not work on the generator set when you are mentally or physically fatigued or have consumed alcohol or drugs.

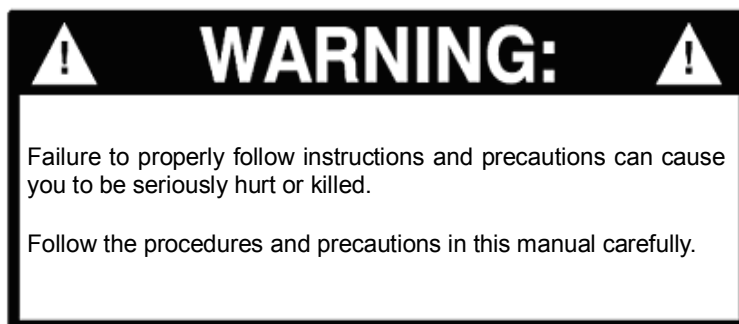
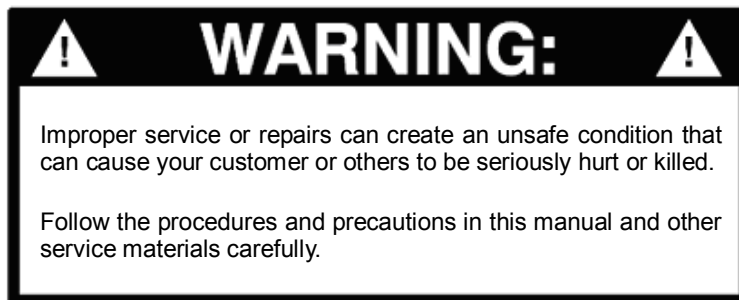

# TABLE OF CONTENTS

---

## SECTION 1 INTRODUCTION

1-1 Generator Components . . . . .	1
1-2 Parameters . . . . .	2

## SECTION 2 MAINTENANCE STANDARD

2-1 Engine Maintenance Standard . . . . .	3
2-2 Generator Maintenance Standard . . . . .	4
2-3 Fastener Torque Specification . . . . .	4
2-4 Standard Fastener Torque Specification . . . . .	4

## SECTION 3 MAINTENANCE

3-1 Maintenance Schedule . . . . .	5
3-2 Engine Oil . . . . .	6
3-3 Air Cleaner . . . . .	7
3-4 Fuel Sediment Cup Cleaning . . . . .	8
3-5 Spark Arrester . . . . .	8
3-6 Spark Plug . . . . .	9
3-7 Valve Clearance . . . . .	10

## SECTION 4 DISASSEMBLY AND SERVICE

4-1 Troubleshooting . . . . .	11
4-1-1 Hard Starting . . . . .	11
4-1-2 Low Power . . . . .	12
4-1-3 Speed Unstable . . . . .	13
4-1-4 Low Speed/Voltage . . . . .	14
4-1-5 Exhaust Color Abnormal . . . . .	15
4-1-6 No AC Output Voltage . . . . .	16
4-2 Preparing to Service . . . . .	17
4-2-1 Safety Precautions . . . . .	17
4-2-2 Special Tools . . . . .	17
4-3 Disassembly Chart . . . . .	18
4-4 Engine . . . . .	19
4-4-1 Camshaft / Piston . . . . .	19

# TABLE OF CONTENTS

---

4-4-2 Cylinder Head / Valves . . . . .	27
4-4-3 Flywheel / Ignition Coil/Recoil Starter . . . . .	33
4-4-4 Carburetor . . . . .	37
4-5 Generator . . . . .	40
4-5-1 Fuel Tank . . . . .	40
4-5-2 Muffler . . . . .	41
4-5-3 Frame/Bedplate Combination . . . . .	43
4-5-4 Motor . . . . .	44
4-5-5 Inverter . . . . .	46
4-5-6 Control Panel . . . . .	48
4-5-7 Outer case assembly . . . . .	51
SECTION 5 WIRING DIAGRAMS . . . . .	52

# SECTION 1. INTRODUCTION

---

## 1-1 Generator Components

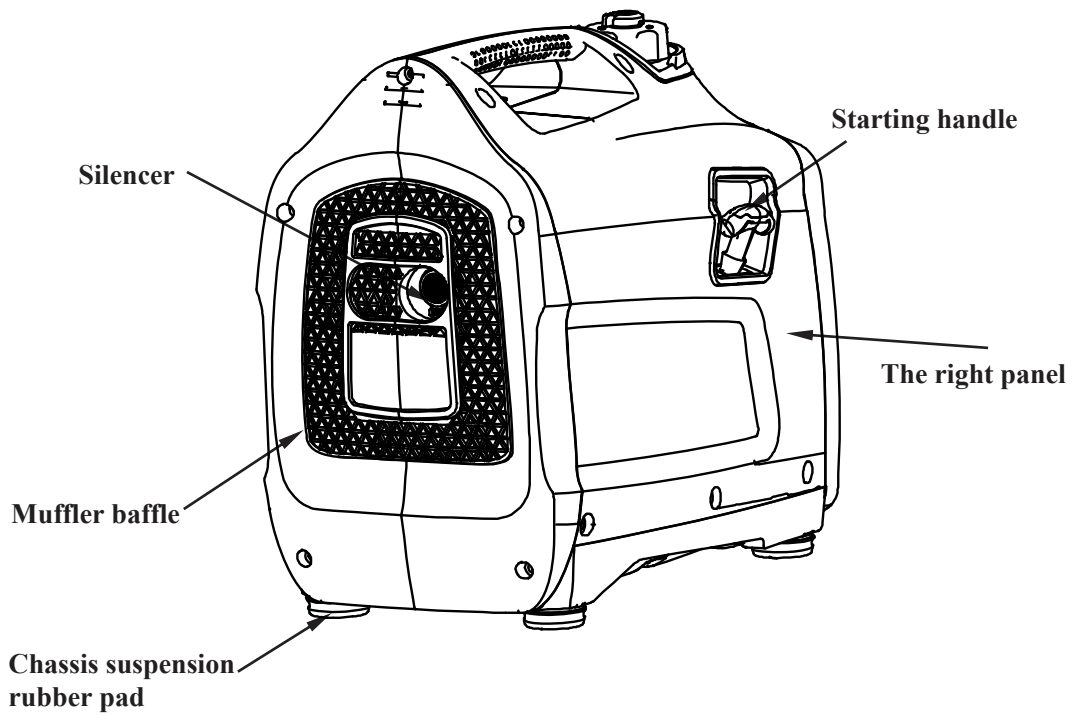
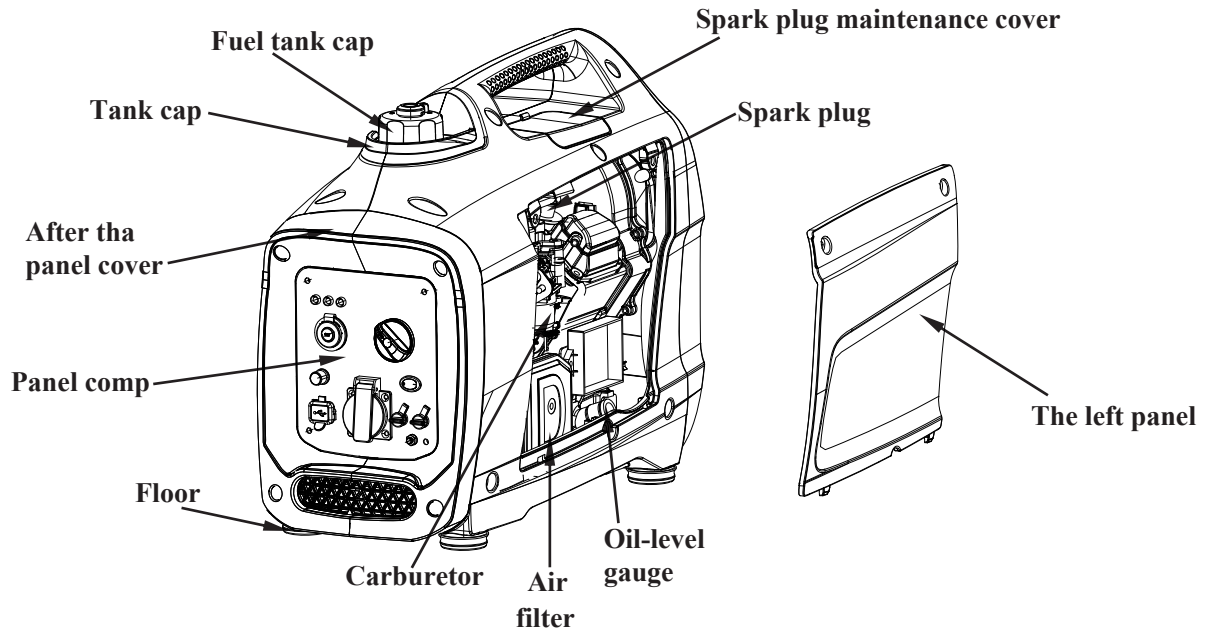

# SECTION 1. INTRODUCTION

---

## 1-2 Parameters

Model No.		P2200i
Generator	Type	Inverter
	Frequency/Hz	50
	Rated Voltage/V	230
	Max. output power /kVA	2.1
	Rated output power /kVA	1.9
	Power factor	1.0
	AC output quality	ISO8528 G1
	THD/%	≤3
	Overload Protection(AC)	Control by inverter overload protection program
Engine	Engine Model No.	DH100i
	Engine Type	Single cylinder, 4-Stroke, forced air cooling, OHV
	Displacement/cc	98
	Fuel Type	Unleaded Gasoline
Engine	Fuel Tank Capacity/L	4.5
	Continuous Running Time/h (at rated output)	3.5
	Engine Oil Capacity/mL	350ml
	Spark Plug Model	E6TC/E6RTC
	Starting Mode	Recoil starter
Dimensions	Length × Width × Height/mm	428×231×369
Net weight/kg		21

# SECTION 2 MAINTENANCE STANDARD

## 2-1 Engine Maintenance Standard

Part	Item	Standard	Allowable limit
Gasoline engine	Max no-load speed Cylinder compression	5000rpm $\cong 1.17\text{Mpa}$ (1400rpm)	6000 rpm --
Cylinder	Cylinder I.D.	52mm	52.015mm
Cylinder head	Warpage	--	0.10mm
Piston	Skirt O.D.	51.98mm	51.97mm
	Piston-to-cylinder clearance	0.015-0.055mm	0.1mm
	Piston pin bore I.D.	11.002 mm	11.04mm
	Piston pin O.D.	10.992mm	10.95mm
	Piston pin-to-piston pin bore clearance	0-0.018mm	0.09mm
Piston rings	Ring side clearance Top/second/oil	0.015-0.045mm	0.15mm
	Ring end gap Top/second	-- 0.2-0.4mm	-- 1.0mm
	Oil	0.15-0.35mm	1.0mm
	Ring width Top/second	1.5mm 2.5mm	1.37mm 2.37mm
	Oil		
Connecting rod	Small end (Pin End) I.D.	11.006mm	11.07mm
	Big end (Crankshaft) I.D.	22.025mm	22.065mm
	Big end oil clearance	0.040-0.063mm	0.12mm
	Small end side clearance	0.4-1.5mm	2mm
Crankshaft	Crankshaft O.D.	21.985mm	21.925mm
Valves	Valve lash IN	0.05±0.02mm	--
	EX	0.05±0.02mm	--
	Stem O.D. IN	4.968mm	4.906 mm
	EX	4.928mm	4.763mm
	Guide I.D. IN/ EX	5.012mm	5.072mm
	Seat width	0.8mm	2.0mm
Spring free length	26.5mm	25mm	
Camshaft	Cam height IN	20.52mm	20.44mm
	EX	20.56mm	20.48mm
	Camshaft O.D.	11.964mm	11.896mm
Crankcase cover	Camshaft-holder I.D.	12mm	12.048mm
Spark plug	Gap	0.7-0.8mm	--
Spark plug cap	Resistance	5kΩ	--

# SECTION 2 MAINTENANCE STANDARD

## 2-2 Generator Maintenance Standard

Table of resistance values between windings rated 230V 1.9kW

Part	Wire color	Resistance
Main winding	Red	4.26Ω±0.34Ω
Secondary winding	White	0.43Ω±0.04Ω
DC winding	Blue	0.113Ω±0.01Ω

## 2-3 Fastener Torque Specification

Part	Fastener size	Tightening torque		
		(N·m)	Kg·m	ft·lb
Cylinder head bolt	M6×1.0	10±1	1.0±0.1	7.5±0.1
Fan cover bolt	M6×1.0	10±1	1.0±0.1	7.5±0.1
Crankcase cover bolt	M6×1.0	12±1	1.2±0.1	9±0.1
Connecting rod cap bolt	M6×1 (special bolt)	10±1	1.0±0.1	7.5±0.1
Air cleaner wing nut	M6×1.0	8±1	0.8±0.1	6±0.1
Muffler mounting nut	M6×1.0	8±1	0.8±0.1	6±0.1
Muffler mounting bolt	M6×1.0	10±1	1.0±0.1	7.5±0.1
Flywheel mounting nut	M12×1.25(special nut)	65±2	6.5±0.1	48.75±2
Breather chamber cap bolt	M6×1	10±1	1.0±0.1	7.5±0.1
Speed-variable stepper motor mounting frame screw	M5×0.8 (special bolt)	8±1	0.8±0.1	18±0.1
Stepper motor screw	M3×0.5	4±1	0.4±0.1	3±0.1
Oil level switch bolt	M6×1	10±1	1.0±0.1	7.5±0.1
Oil level switch holder plate bolt	M6×1	10±1	1.0±0.1	7.5±0.1
Ignition coil bolt	M6×1	10±1	1.0±0.1	7.5±0.1

## 2-4 Standard Fastener Torque Specification

Standard torque values	5 mm bolt, nut	4-7 (40-70, 2.9-5.1)
	6 mm bolt, nut	8-12 (80-120, 5.8-8.7)
	8 mm bolt, nut	20-28 (200-280, 14.5-20.2)
	10 mm bolt, nut	35-40 (350-400, 14.5-20.2)
	12 mm bolt, nut	50-60 (500-600, 36.2-43.4)

# SECTION 3 MAINTENANCE

## 3-1 Maintenance Schedule

Good maintenance is essential to safe, economical and zero-failure operation, and is also good for environment protection. Under hot or dusty operating conditions some maintenance operations should be performed more frequently, as indicated by the footnotes to the table.

Keep a log of maintenance performed and the hours run. Recording maintenance will help you keep it regular and provide a basis for supporting warranty claims.

**⚠ WARNING** *Accidental starting of the generator set during maintenance can cause severe personal injury or death. Before performing maintenance, disconnect the spark plug wire from the spark plug.*

**⚠ WARNING** *A hot generator set can cause severe burns. Always allow the generator set to cool adequately before performing any maintenance or service.*

### PERIODIC MAINTENANCE SCHEDULE

SERVICE ITEMS		EACH USE	FIRST MONTH OR 20 HOURS(3)	EVERY 3 MONTHS OR 50 HOURS(3)	EVERY 6 MONTHS OR 100 HOURS	EVERY YEAR OR 300 HOURS
Engine oil	Check oil level	○				
	Replace		○		○	
Air cleaner	Check	○				
	Clean			○(1)		
Fuel sediment cup	Clean				○	
Spark arrestor	Clean				○	
Spark plug	Clean				○	Replace
Valve clearance	Readjust					○(2)
Cylinder head	Wash	Every 500 hours (2)				
Fuel tank and strainer	Wash	Every 2 years (2)				
Fuel line	Replace	Every 2 years (2)				

(1) Service more frequently when it is used in dusty environments.

(2) These items must be performed by a dealer franchised by Loncin

(3) When the set is used frequently, the correct maintenance intervals above must be followed to ensure long-time use.

# SECTION 3. MAINTENANCE

## 3-2 Engine Oil

**NOTE: Drain the oil while the engine is still warm to assure rapid and complete draining.**

- 1) Place the generator on a level surface and warm up for several minutes.
- 2) Remove the screw ①, and then remove the oil fill cover ②.

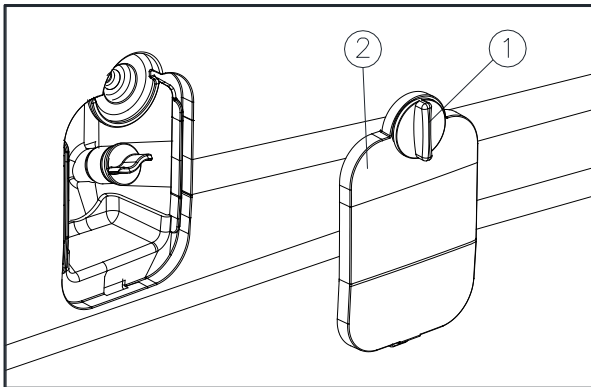

- 3) Remove the oil filler cap ③.

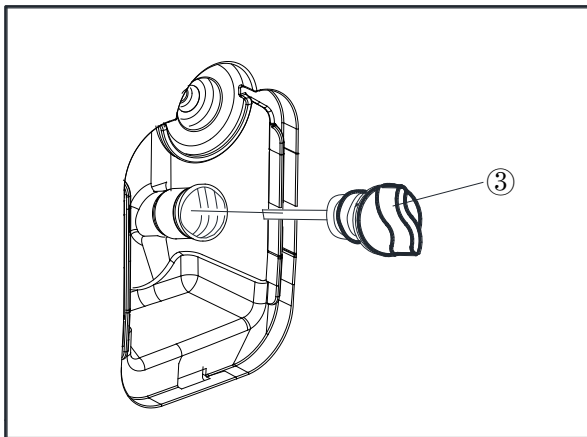

- 4) Place an oil pan under the engine. Tilt the generator to drain the oil completely.
- 5) Place generator on a level surface.
- 6) Fill with the recommend amount and type of engine oil, then install and tighten the oil filler cap (See Specification section for oil type and capacity).

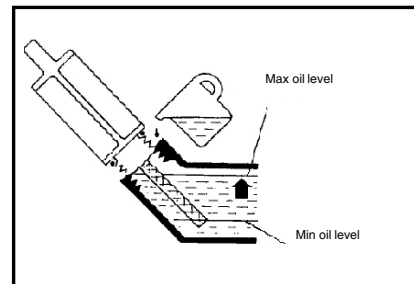

**Note:** Before each time of use, the generator must be placed on a horizontal surface and check the oil level after stopping the engine.

1. Remove the oil dipstick and wipe it clean
2. Insert dipstick into oil filler hole but don't tighten it, check oil level.
3. If oil level is too low, add the recommended engine oil until oil level reaches the upper limited shown by the dipstick.

Recommended engine oil:

SAE 10W -30

Recommended engine oil grade:

API Service SE type or higher

Engine oil quantity:

0.35 L (0.42 US qt, 0.35 Imp qt)

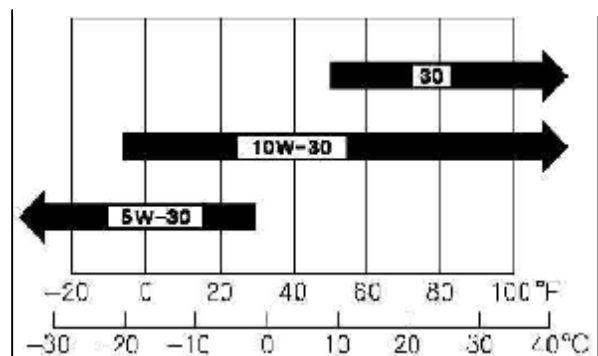

**⚠ WARNING** Used motor oil may cause skin cancer if repeatedly left in contact with the skin for prolonged periods. Thoroughly wash your hands with soap and water as soon as possible after handling used oil though the cancer is not certain to occur.

# SECTION 3. MAINTENANCE

## 3-3 Air Cleaner

**CAUTION** A dirty air cleaner will restrict air flow to the carburetor, causing a lower engine power. Service air cleaner more frequently when operating the generator in extremely dusty areas.

**WARNING** Using gasoline or flammable solvent to clean the filter element can cause a fire or explosion. Use only soapy water or nonflammable solvent.

**WARNING** Never run the generator without the air cleaner. Rapid engine wear will result.

- 1) Remove the cleaner cover ② by loosening the screws . Clean more often in dusty environment ①.
- 2) Remove the screw ③ , and detach air cleaner cover ④.

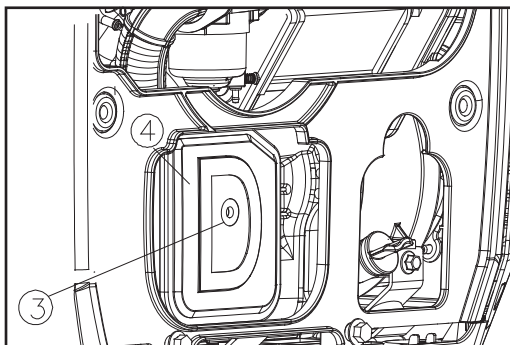
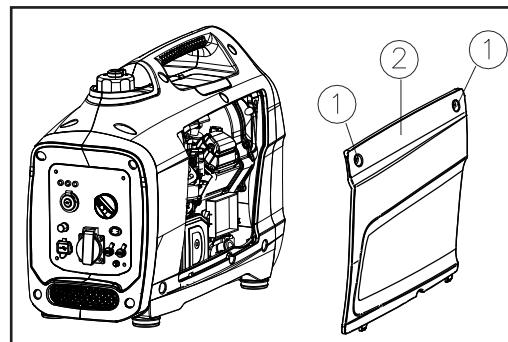

- 3) Remove the filter elements ①
- 4) Wash the foam filter element with solvent and dry it thoroughly
- 5) Drip some clean engine oil into each foam filter element and knead to squeeze out excess oil and let the oil be distributed evenly throughout each filter element.

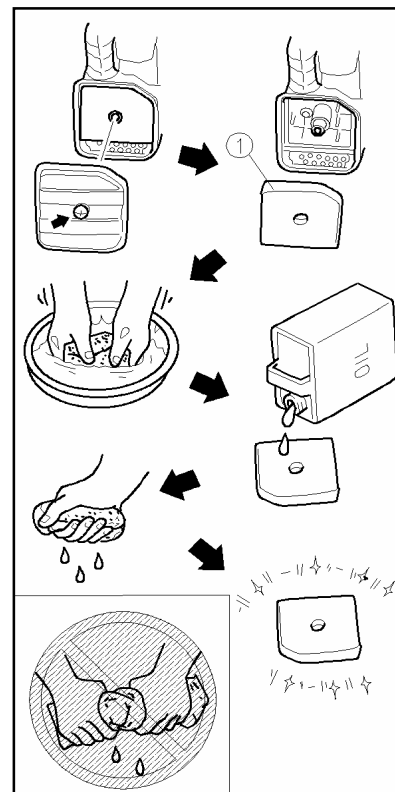

# SECTION 3. MAINTENANCE

## 3-4 Fuel Sediment Cup Cleaning

The fuel sediment cup prevents dirt or water which may be in the fuel tank from entering the carburetor. If the generator has not been run for a long time, the sediment cup should be cleaned.

- 1) Remove screw ① and detach cover ②, then drain off fuel from fuel tank ③
- 2) Hold and move downward the clamp ④, then pull off the hose ⑤ from the tank
- 3) Take out the fuel filter ⑥
- 4) Wash the fuel filter with gasoline
- 5) Wipe dry the fuel filter and put it back into tank
- 6) Reinstall the hose and clamp, then open the fuel valve to check whether it has leak
- 7) Reinstall the cover and tighten the screws.

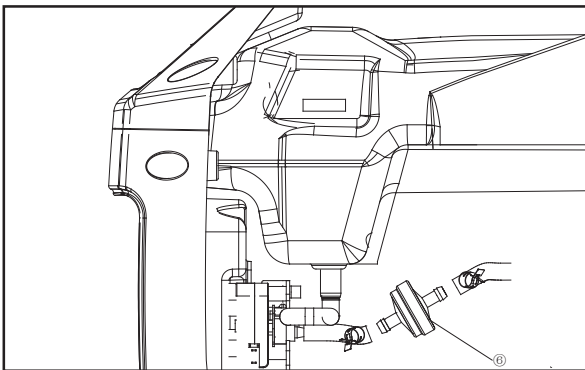
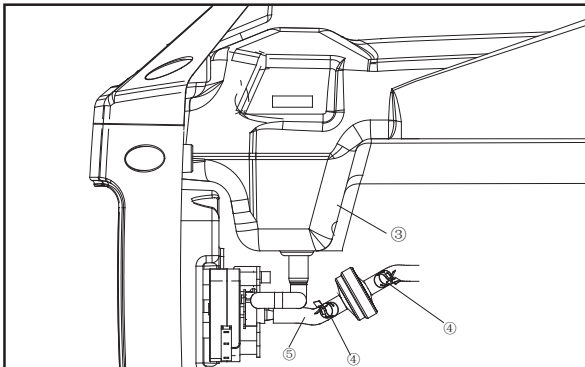

**⚠ WARNING** Gasoline is extremely flammable and explosive. Do not smoke or allow flames or sparks in the work area.

**⚠ WARNING** After reassembly, check for leaks, and make sure the work area is dry before starting the engine.

## 3-5 Spark Arrester

**⚠ WARNING** A hot muffler can cause severe burns. Allow the generator set to cool before servicing the muffler.

Refer to MAINTENANCE SCHEDULE for scheduled spark arrester cleaning. After letting the generator set cool down, remove the spark arrester screen. Inspect for damage, and replace if it is defective. Clean any deposits on the screen with a wire brush. Reinstall the spark arrester, and tighten the screw securely.

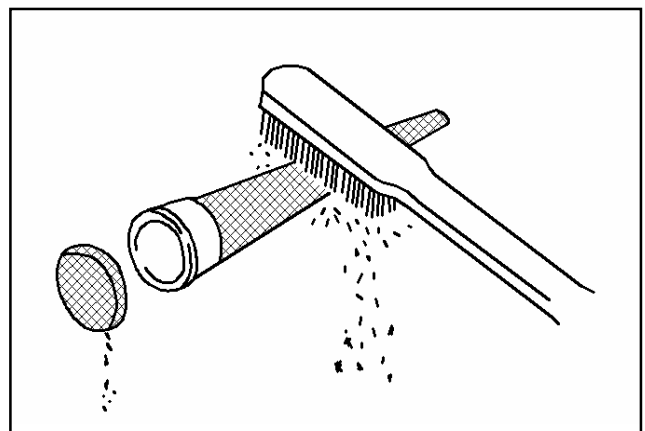
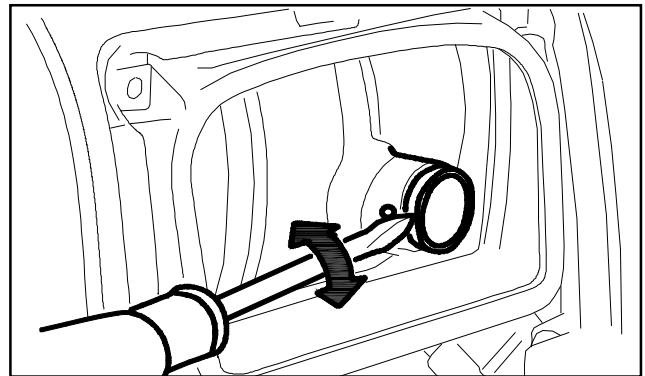

# SECTION 3. MAINTENANCE

## 3-6 Spark Plug

A spark plug of a wrong model or wrong heat range may deteriorate the engine's performance or even damage the engine.

If the engine is run continuously, the spark plug and muffler will be very hot. Be careful not to touch the muffler or spark plug.

Turn off generator, remove spark plug maintenance cover ① and spark plug cap ②, and insert the tool ④ through the hole from the outside of the cover.

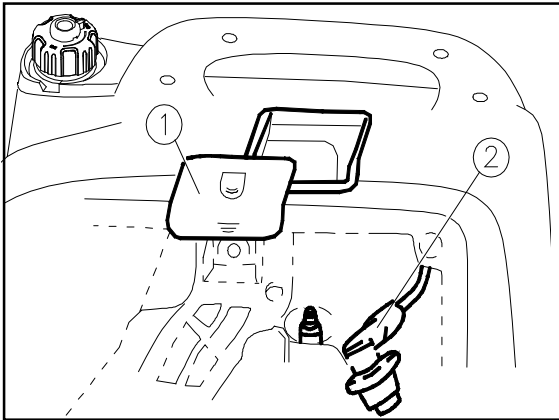

- 1) Insert the handlebar ③ into the tool ④ and turn it counterclockwise to remove the spark plug.

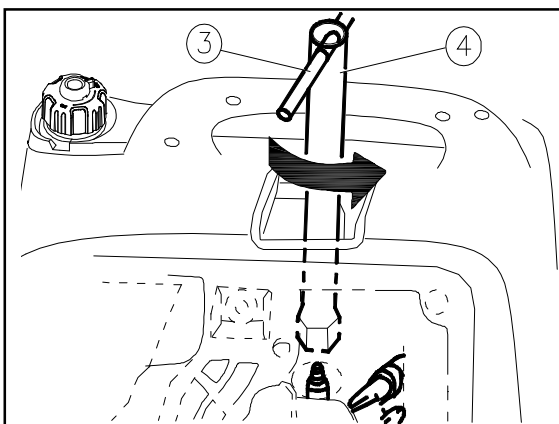

- 2) Check the spark plug. Spark plug model:  
E6TC/E6RTC  
BP6HS / BPR6HS (NGK)  
L87YC / R L87YC (CHAMPION)

W16FP / W16FPR (DENSO)

W6BC / WR6BC (BOSCH)

If the machine needs EMC Certification, engine must use E6RTC spark plug

If the electrode is damaged, or insulation is cracked or chipped, replace the spark plug. If it can still be used, use a wire brush to remove carbon or other deposits from the spark plug.

- 3) Measure the plug gap with a feeler gauge. Correct as necessary by carefully bending the side electrode. The gap should be 0.60-0.70 mm.

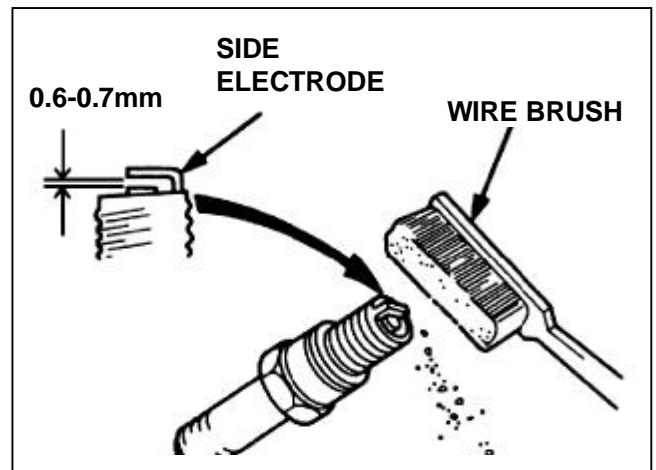

- 4) Check that the spark plug washer is in good condition, and thread the spark plug in by hand to prevent cross-threading.
- 5) After the spark plug seats on the washer, tighten with a spark plug wrench to firmly press on the washer.

If installing a new spark plug, tighten 1/2 turn after the spark plug has firmly pressed on the washer. If reinstalling a used spark plug, tighten 1/8 - 1/4 turn after the spark plug has firmly pressed on the washer.

**Spark Plug Torque: 20.0 N\*m (2.0kgf\*m, 14.8 lbf\*ft)**

**CAUTION** The spark plug must be securely tightened. An improperly tightened spark plug could damage the engine.

**CAUTION** Never use spark plugs which have an improper heat range. Use only the recommended spark plugs or equivalent.

# SECTION 3. MAINTENANCE

## 3-7 Valve Clearance

**CAUTION** Valve clearance inspection and adjustment must be performed with the engine cold.

- 1) Remove the cylinder head cover, and pull the starter grip (until a resistance is clearly felt) to set the piston at top dead center of the compression stroke (both valves fully closed).
- 2) Insert a feeler gauge between the rocker arm and valve to measure valve clearance.

Standard valve clearance	IN.	$0.08 \pm 0.12$ mm
	EX.	$0.13 \pm 0.17$ mm

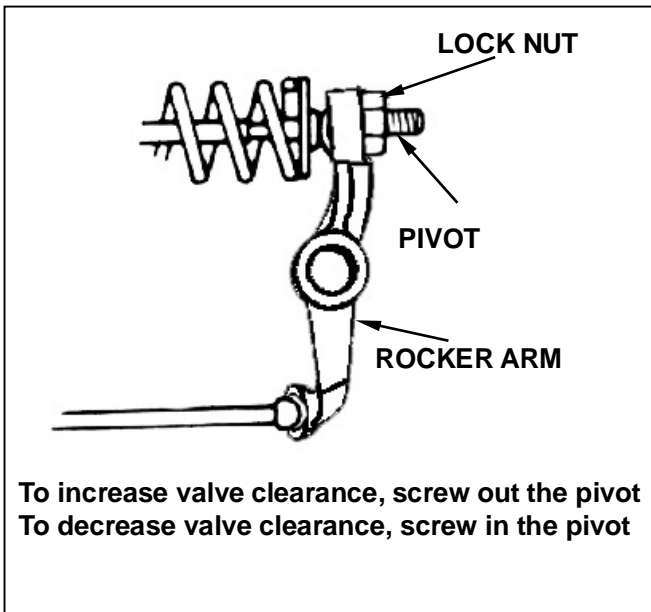

- d) Recheck valve clearance after tightening the lock nut.

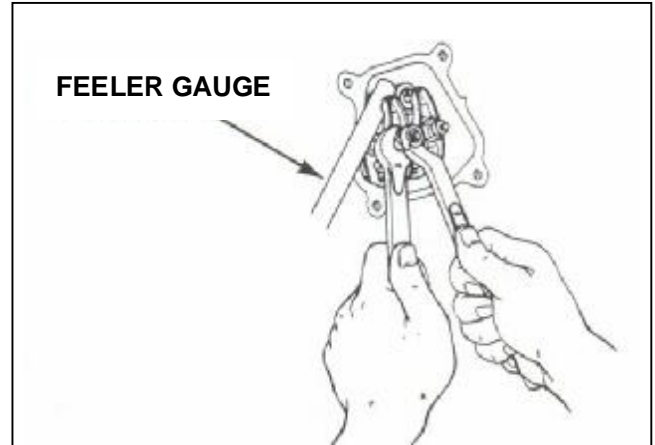

- 3) If adjustment is necessary, proceed as follows:
  - a) Use a clamp to hold the rocker arm pivot and use a wrench to loosen the pivot lock nut.
  - b) Turn the rocker arm pivot to obtain the specified valve clearance.
  - c) Retighten the lock nut while using a clamp to hold the rocker arm pivot.

# SECTION 4. DISASSEMBLY AND SERVICE

## 4-1 Troubleshooting

### 4-1-1 Hard Starting

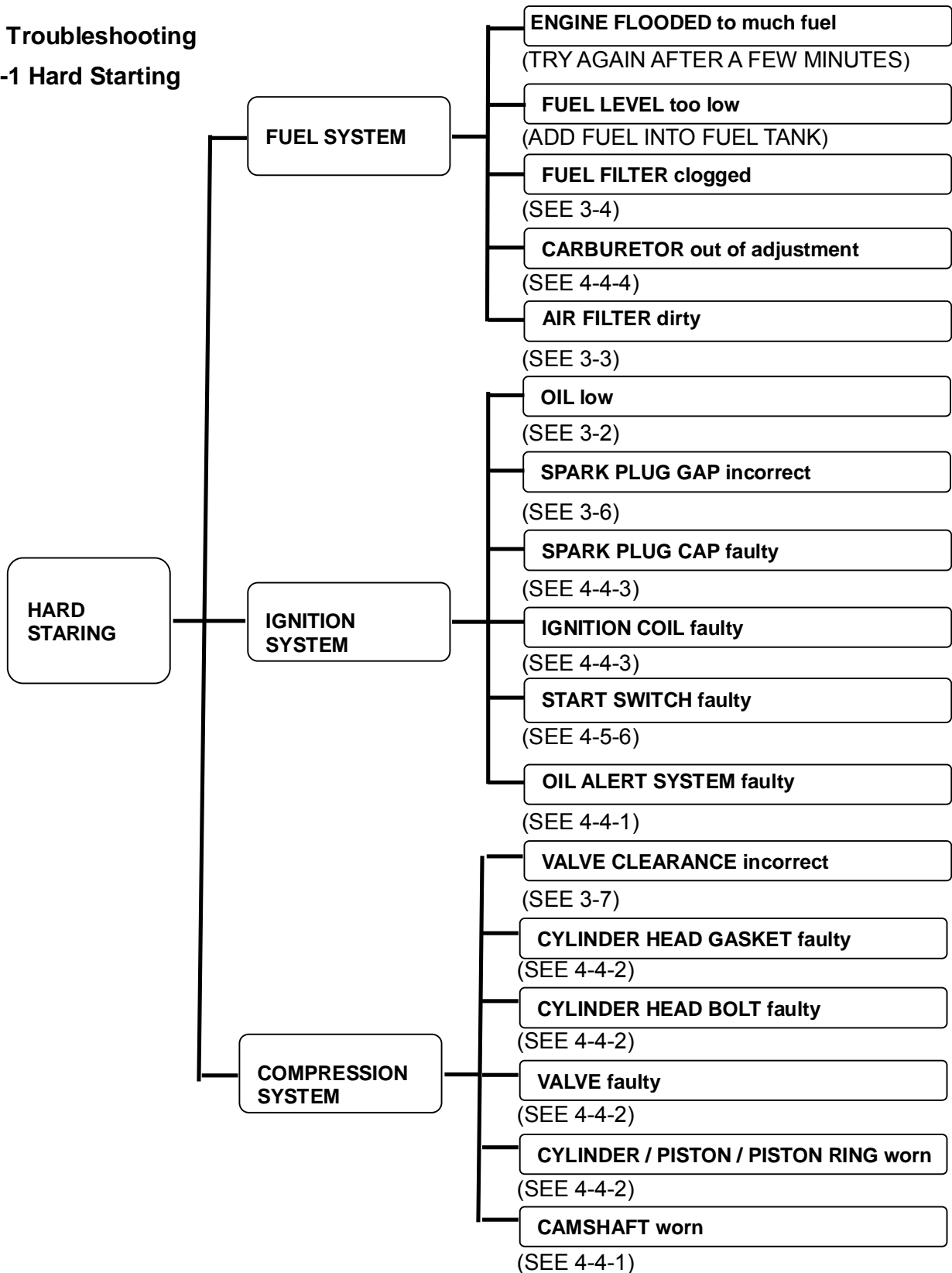

# SECTION 4. DISASSEMBLY AND SERVICE

## 4-1-2 Low Power

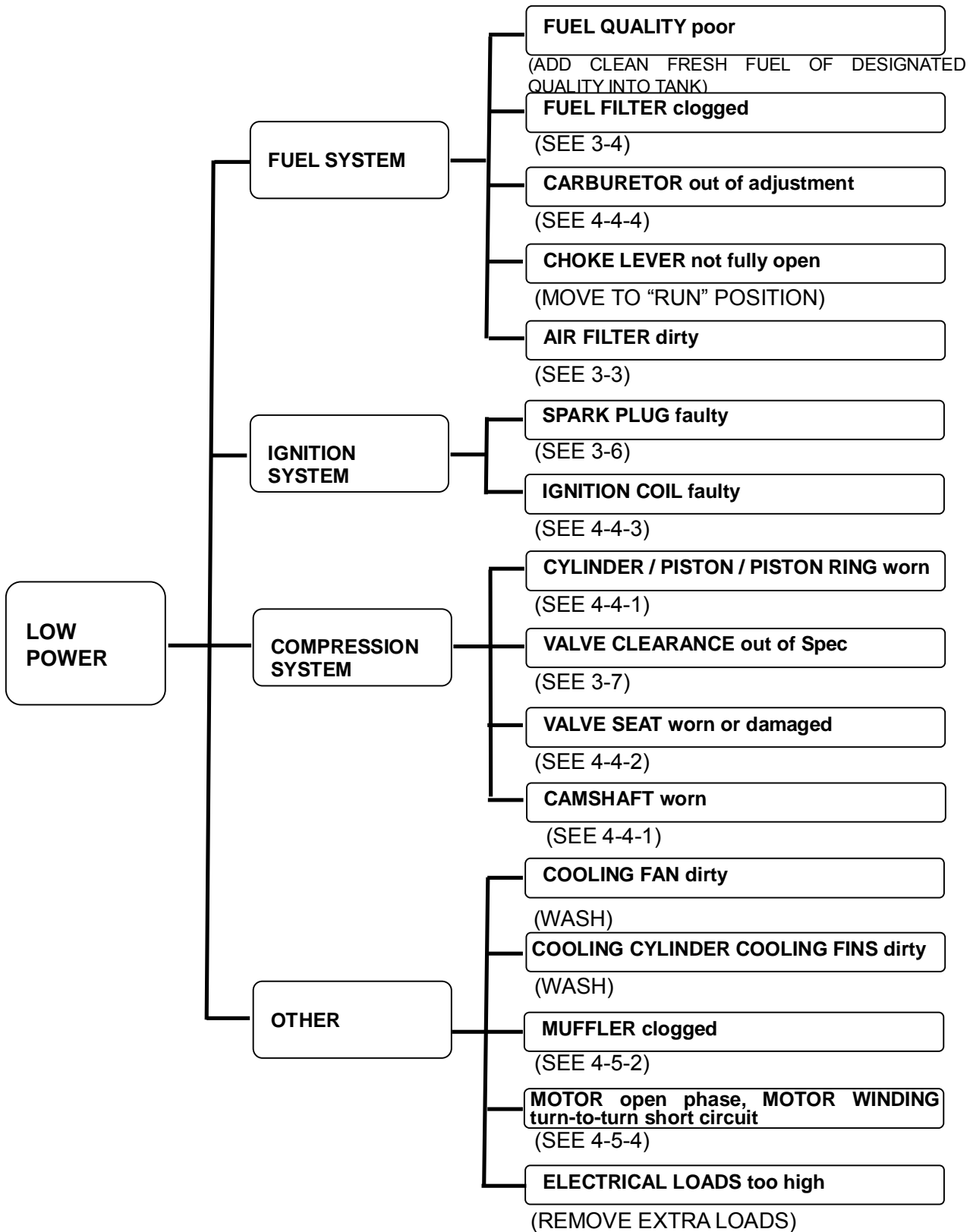

# SECTION 4. DISASSEMBLY AND SERVICE

## 4-1-3 Speed Unstable

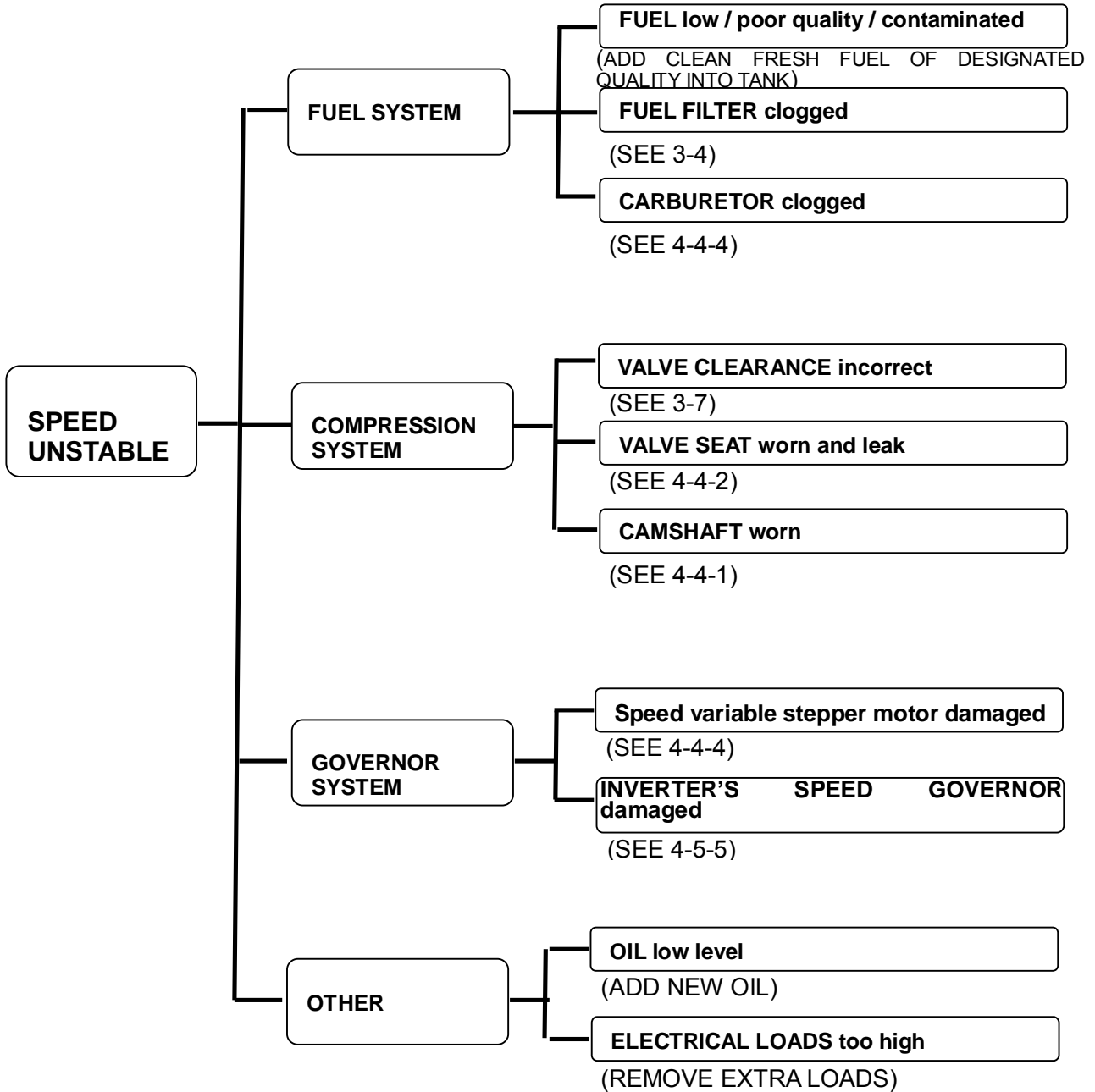

# SECTION 4. DISASSEMBLY AND SERVICE

## 4-1-4 Low Speed / Voltage

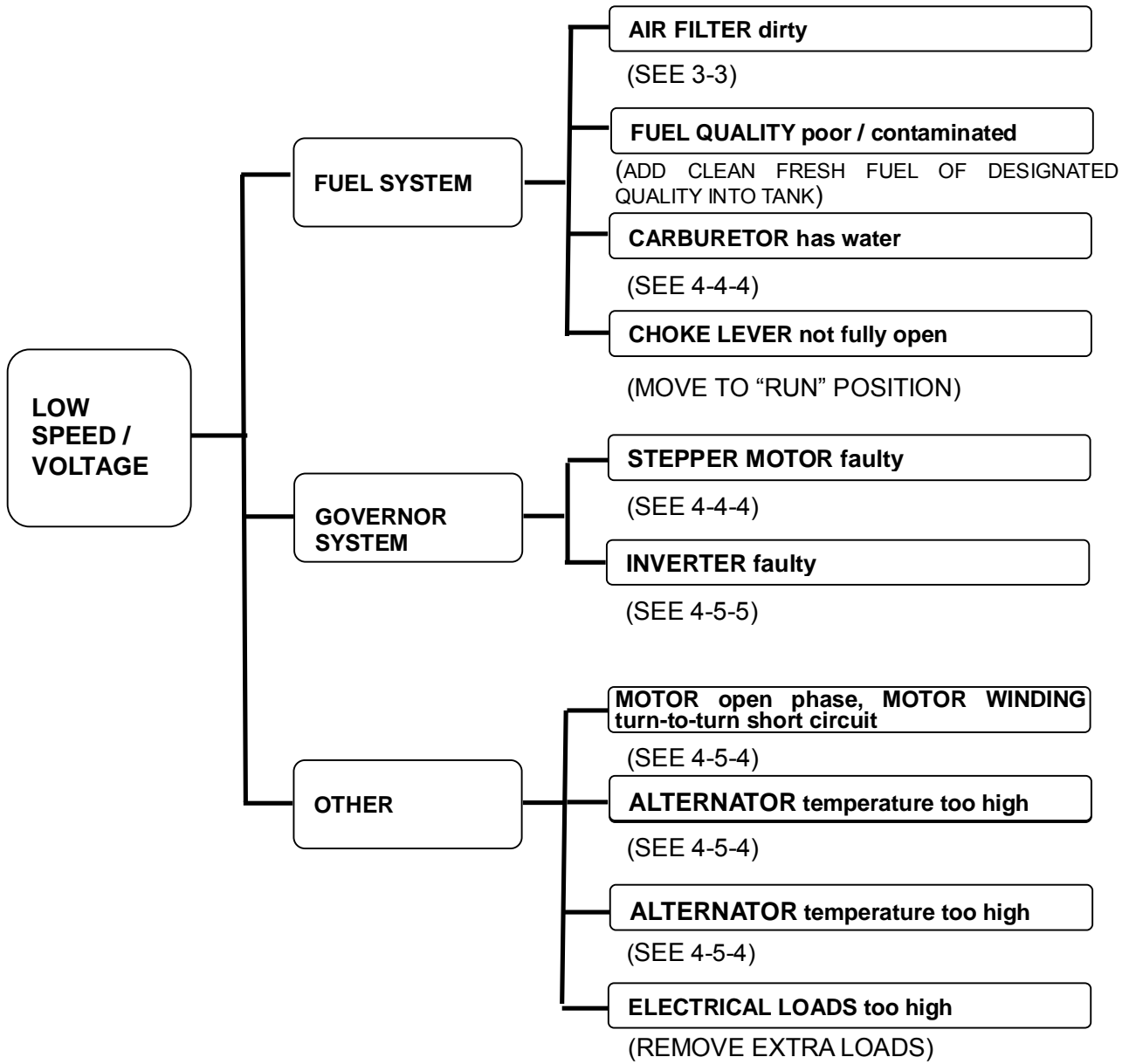

# SECTION 4. DISASSEMBLY AND SERVICE

## 4-1-5 Exhaust Color Abnormal

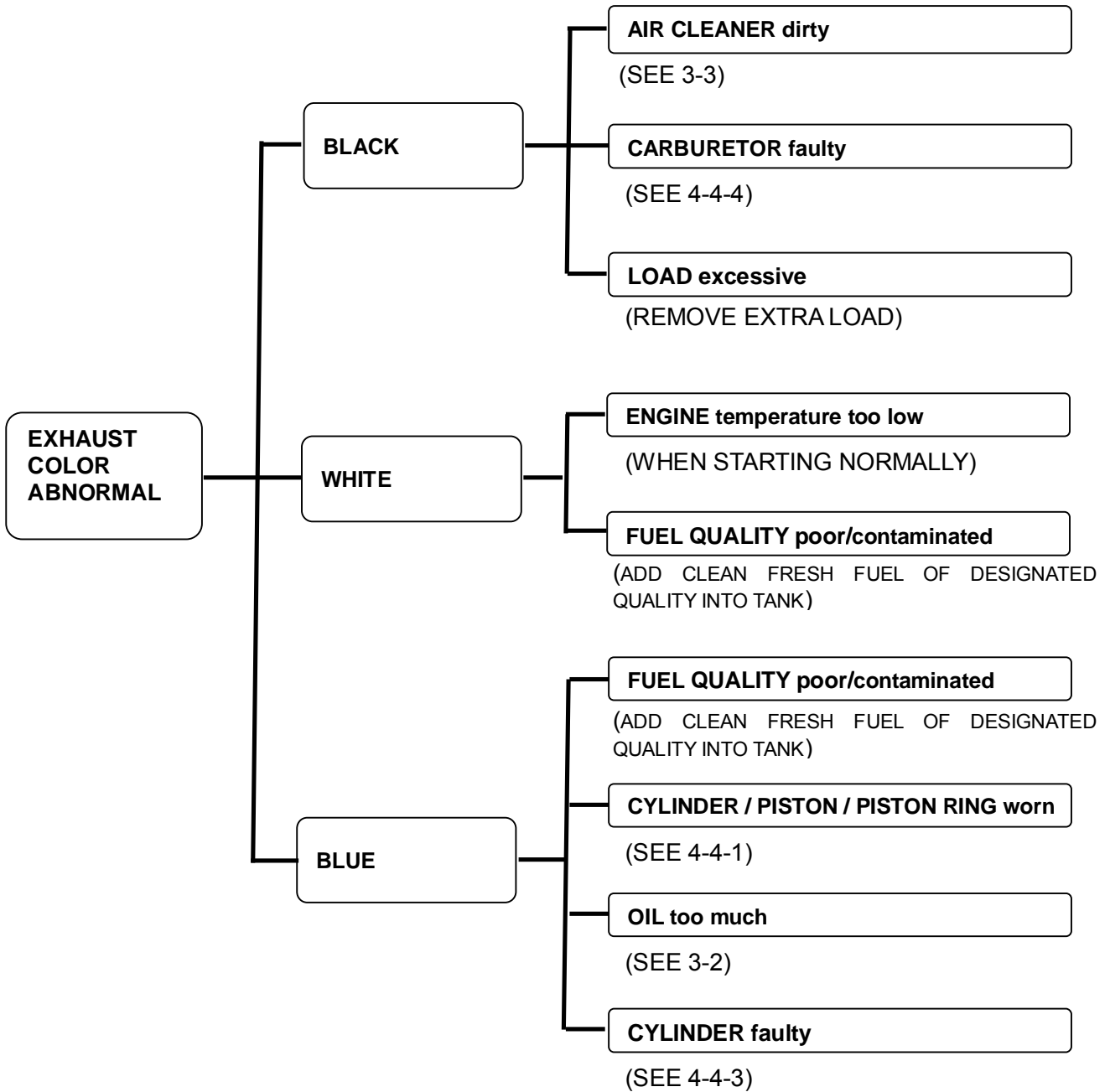

# SECTION 4. DISASSEMBLY AND SERVICE

---

## 4-1-6 No AC Output Voltage

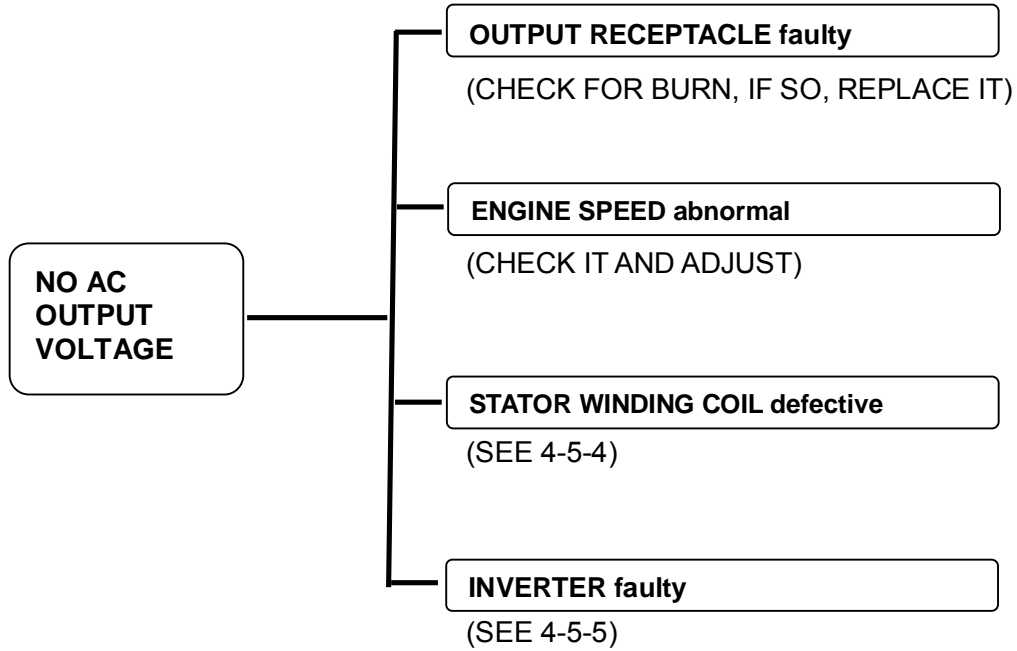

# SECTION 4. DISASSEMBLY AND SERVICE

## 4-2 Preparing to Service

### 4-2-1 Safety Precautions

There are hazards in servicing gensets. Study Safety precautions and become familiar with the hazards listed in table 4-1. Note the following safeguards and ways of avoiding hazards.

- **Use personal protection:** Wear appropriate protective safety equipment, such as safety shoes and safety glasses.

- Do not wear rings or jewelry and do not wear loose or damp clothing that might get caught in equipment or conduct electricity.

- **Reduce the hazard:** A safe, orderly and well-maintained workshop reduces the hazard potential. Keep guards and shields in place on machinery and maintain equipment in good working condition. Store flammable liquids in approved containers; away from fire, flame, spark, pilot torch, switches, arc-producing equipment and other ignition sources. Keep the workshop clean and well-lighted and provide adequate ventilation.

- **Develop safe work habits:** Unsafe actions cause accidents of tools and machines. Be familiar with the equipment and know how to use them safely. Use the correct tool for the job and check its condition before starting. Comply with the warnings in this manual and take special precautions when working around electrical equipment. Do not work alone if possible and take no risks.

- **Be prepared for an accident:** Keep fire extinguishers and safety equipment nearby. Agencies such as the Red Cross and public safety departments offer courses in first aid, CPR and fire control. Take advantage of this information to be ready to respond to an accident. Learn to be safety-conscious and make safety procedures part of the work routine.

**TABLE 4-1 HAZARDS AND THEIR SOURCES**

Fire and Explosion	<ul style="list-style-type: none"> <li>• Leaking or spilled fuel</li> <li>• Hydrogen gas from battery</li> <li>• Oily rag improperly stored</li> <li>• Flammable liquids improperly stored</li> </ul>
Burns	<ul style="list-style-type: none"> <li>• Hot exhaust pipes</li> <li>• Hot engine and generator surfaces</li> </ul>
Poisonous exhaust	<ul style="list-style-type: none"> <li>• Operating genset in a place without ventilation, or indoors</li> </ul>
Electrical shock (AC)	<ul style="list-style-type: none"> <li>• Improper generator connections</li> <li>• Faulty wiring</li> <li>• Working in damp conditions</li> <li>• Metal object touching electrical components</li> </ul>
Rotating machinery	<ul style="list-style-type: none"> <li>• Fan guards not in place</li> </ul>
Slippery surfaces	<ul style="list-style-type: none"> <li>• Leaking or spilled oil</li> </ul>
Heavy objects	<ul style="list-style-type: none"> <li>• Removing genset from vehicle</li> <li>• Removing heavy components</li> </ul>

### 4-2-2 Special Tools

#### Engine

A complete set of standard and metric shop tools are required for servicing the engine.

#### Control and Generator

A complete set of standard and metric shop tools are required for servicing the control and generator. Also needed are:

- ≥ Lead or soft-face dead blow hammer
- ≥ Torque wrench
- ≥ VOM meter
- ≥ Frequency meter
- ≥ Armature growler
- ≥ Load bank
- ≥ Rotor Puller

# SECTION 4. DISASSEMBLY AND SERVICE

## 4-3 Disassembly Chart

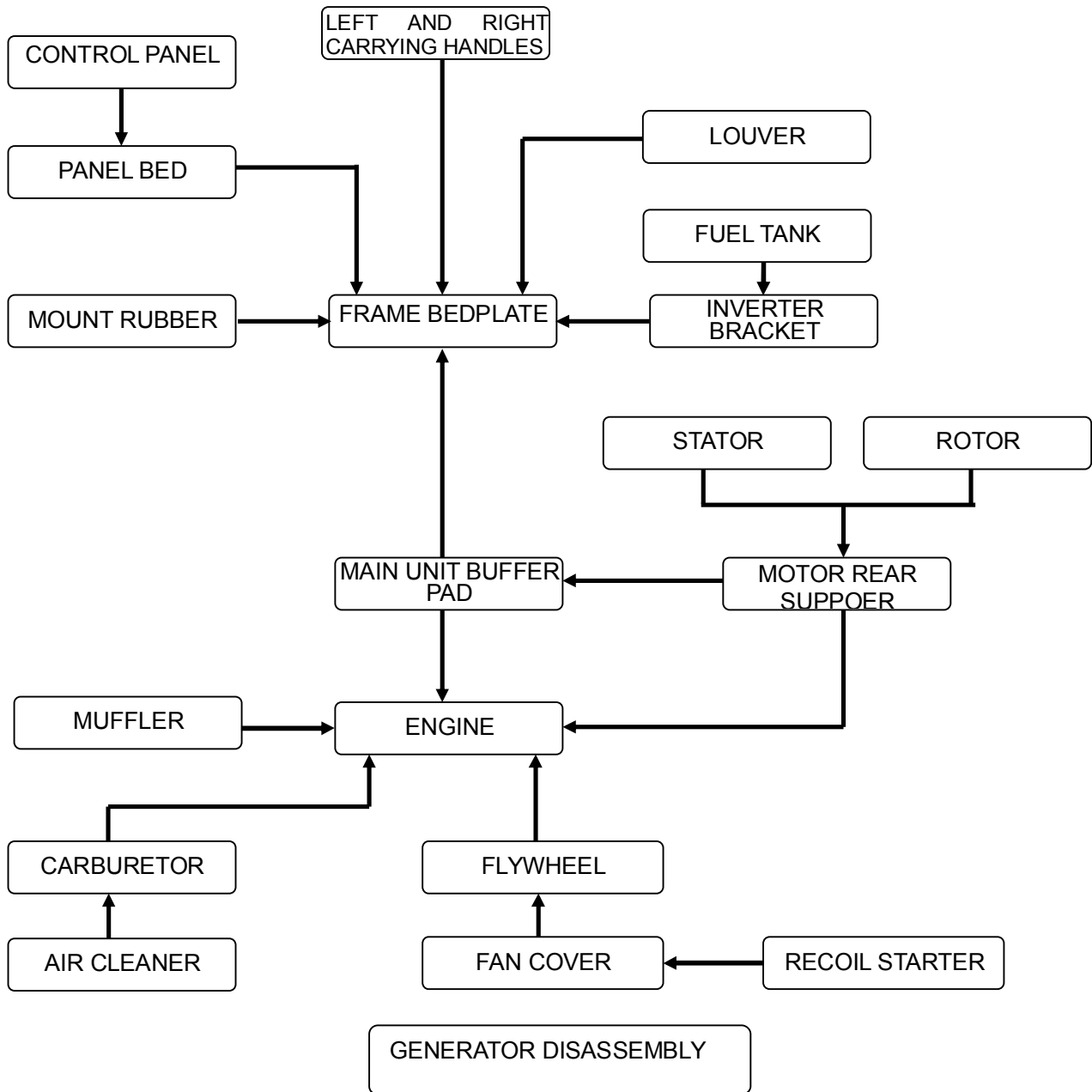

This chart is a quick-reference guide for disassembling the product. Be sure to follow the sequence shown here for better and safer work.

# SECTION 4. DISASSEMBLY AND SERVICE

## 4-4 Engine

### 4-4-1 Camshaft / piston

#### a. DISASSEMBLY/ REASSEMBLY

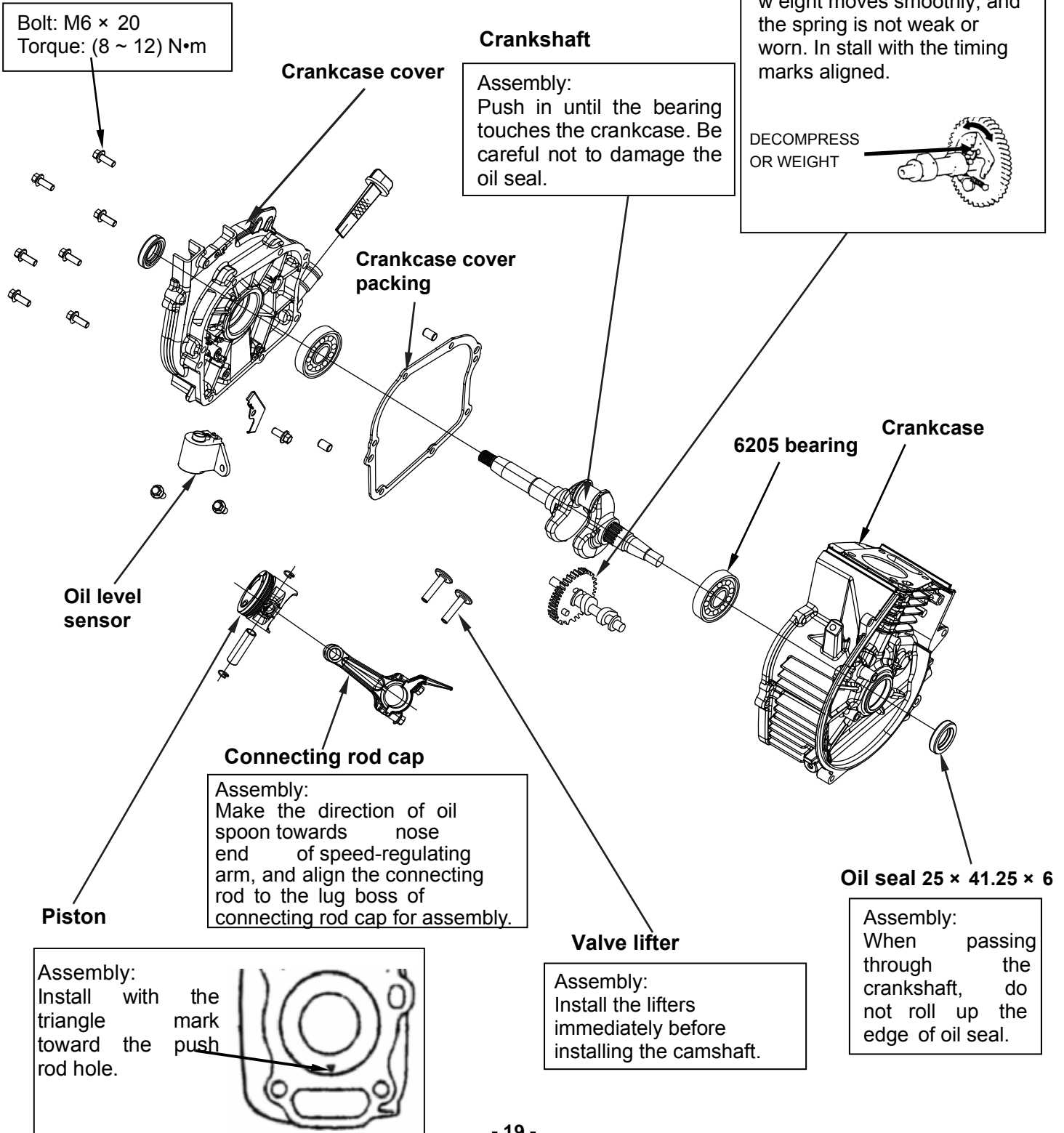

# SECTION 4. DISASSEMBLY AND SERVICE

## b. PISTON/ PISTON RING

### PISTON RING

#### REASSEMBLY:

- 1) Install all rings with the markings facing upward.
- 2) Be sure that the top (chrome plated) and second rings are not interchanged.
- 3) Check that the rings rotate smoothly after installation.
- 4) Set the piston ring end gaps 120 degrees apart, and do not align the gaps with the piston pin bore.

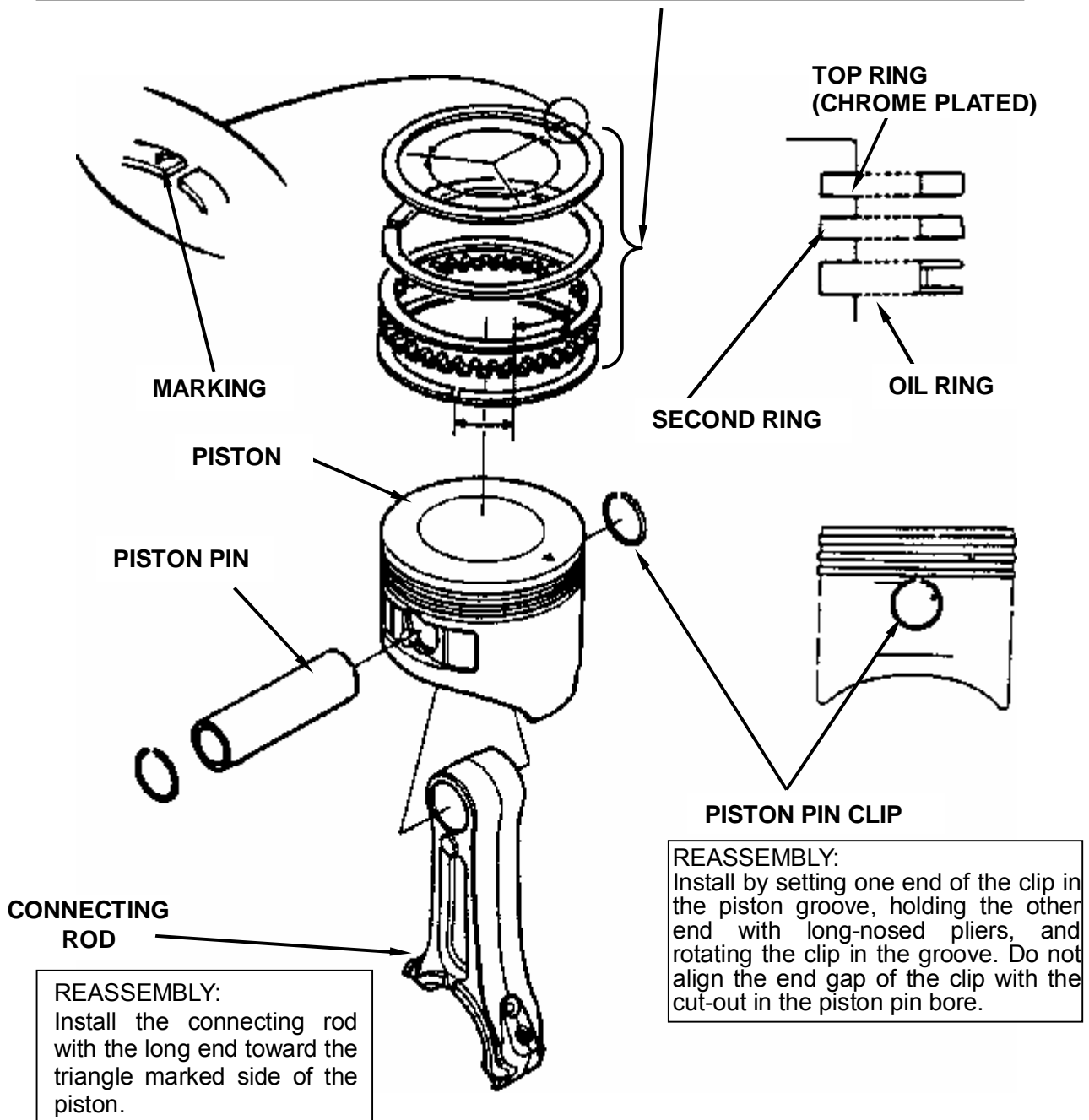

# SECTION 4. DISASSEMBLY AND SERVICE

## c. CAMSHAFT/ CRANKSHAFT

While installing the camshaft, align the punch marks on the camshaft gear and timing gear (small gear on the crankshaft.)

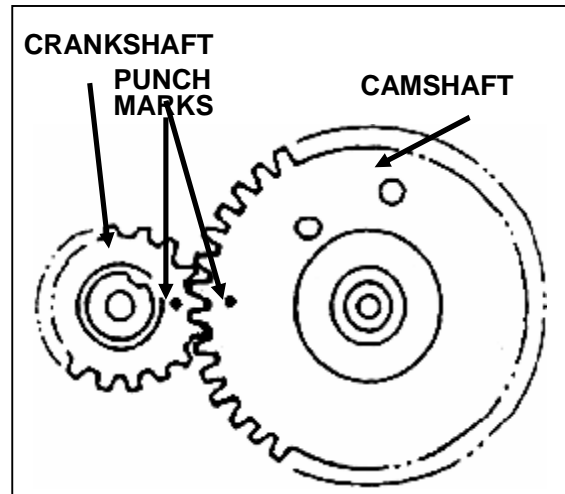

## d. INSPECTION

### PISTON

Check contact between piston and cylinder, defect of ring grooves, burn of piston top, cracks, etc. If the damage is severe, such as cracks, replace the piston.

### REMOVAL OF CARBON DEPOSIT

Carbon deposit forms on piston top and upper edge of cylinder bore, carbon deposit should be removed before check. Use kerosene to drench the part with carbon deposit, then use a blunt scraping knife or a wire brush to remove carbon deposit.

### 1) PISTON SKIRT O.D.

Use a outside micrometer to measure piston skirt O.D., if it is out of service limit, replace it.

Standard	Service limit
51.98 mm	51.97 mm

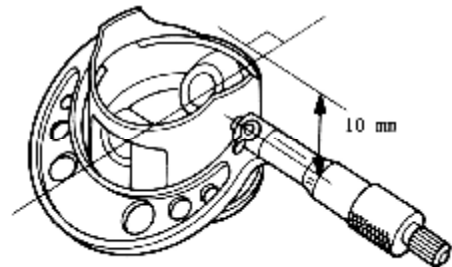

### 2) PISTON-TO-CYLINDER CLEARANCE

Difference between cylinder's maximum diameter and piston skirt diameter is the piston-to-cylinder clearance.

Standard	Service limit
0.15-0.045 mm	0.1 mm

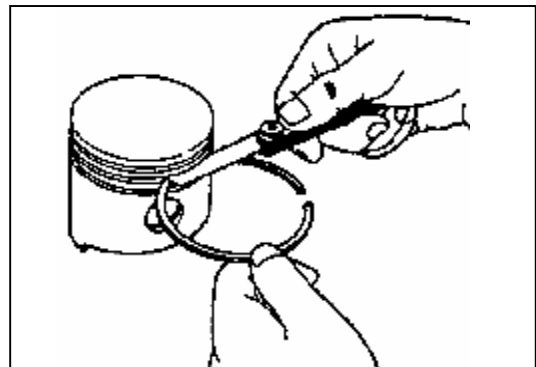

### 3) PISTON RING SIDE CLEARANCE

When checking, put all rings in their grooves, they should be able to rotate freely without loosening or sticking. Then insert the feeler gauge into clearance between each ring

# SECTION 4. DISASSEMBLY AND SERVICE

and groove's upper or lower surface to measure the clearance.

Standard	Service limit
0.015-0.045 mm	0.15 mm

## 4) PISTON RING WIDTH

	Standard	Service limit
Top/Second	1.5 mm	1.37 mm

## 5) PISTON RING END GAP

	Standard	Service limit
Top/second	0.02-0.04 mm	1.0 mm

Before measuring, put piston rings correctly in the ring grooves, then, put the piston into the cylinder. As rings are used in a set, top ring and second ring should be replaced together.

## 6) PISTON PIN O.D.

Standard	Service limit
10.992	10.932 mm

## 7) PISTON PIN BORE I.D.

Standard	Service limit
11.002 mm	11.04 mm

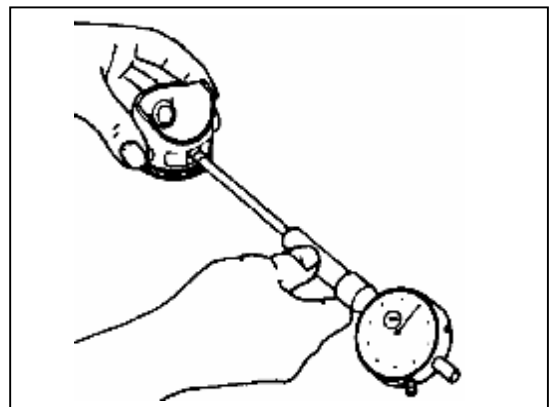
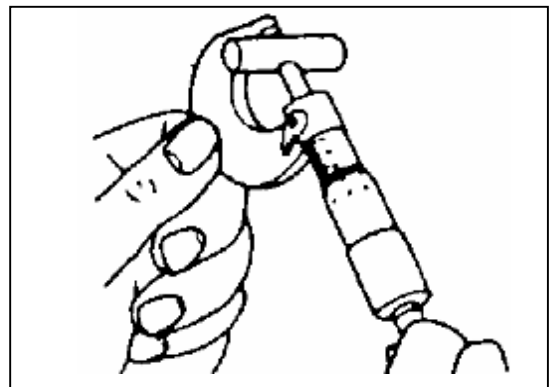
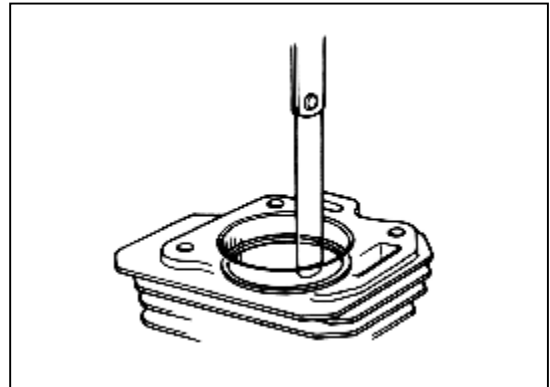
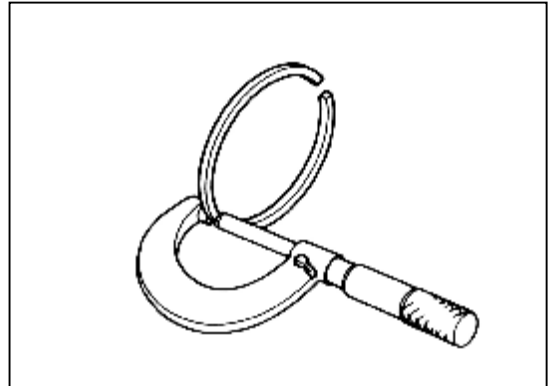

# SECTION 4. DISASSEMBLY AND SERVICE

## 8) PISTON PIN-TO-PISTON PIN BORE CLEARANCE

Use an inside micrometer and an outside micrometer to measure piston pin bore's inside diameter and piston pin's outside diameter, then use the measured values to calculate the difference; if difference is beyond service limit, replace piston or piston pin according to wear status.

Standard	Service limit
0.005-0.015 mm	0.06 mm



## 9) CYLINDER I.D.

Standard	Service limit
48.6 mm	48.765 mm

## CONNECTING ROD

If the connecting rod is bent or twisted, or its big end's bearing bush and small end shaft housing's outer ring has play, or one of its sides has cracks, the connecting rod must be scrapped and replaced with a new one.

### 1) CONNECTING ROD SMALL END I.D.

If it is smaller than standard, or beyond service limit, replace the connecting rod.

Standard	Service limit
11.006 mm	11.07 mm

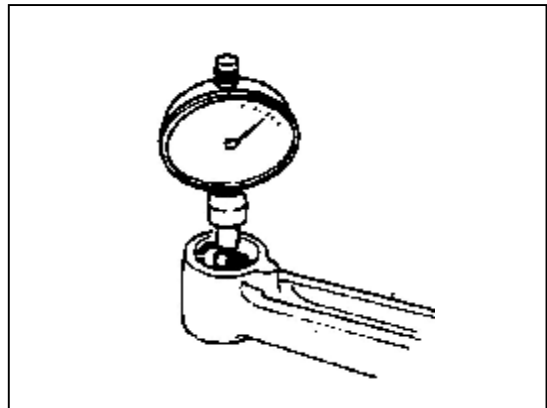

### 2) CONNECTING ROD BIG END I.D.

If it is smaller than standard, or beyond service limit, replace the connecting rod.

Standard	Service limit
22.025 mm	22.065 mm

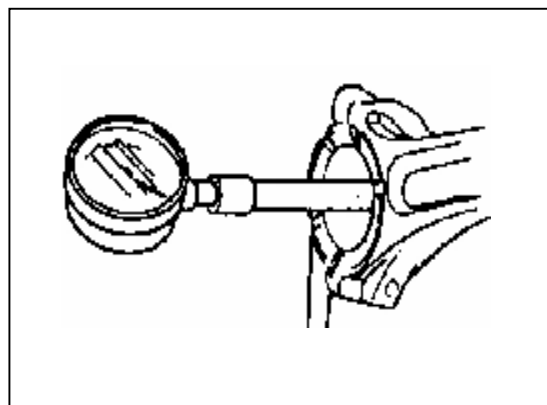

# SECTION 4. DISASSEMBLY AND SERVICE

## 3) CRANKPIN O.D.

Standard	Service limit
21.985 mm	21.925 mm

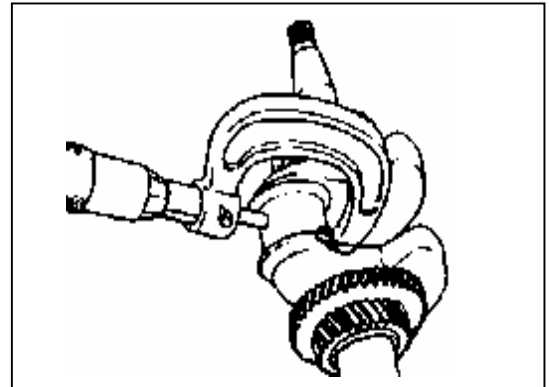

## 4) CONNECTING ROD BIG END SIDE CLEARANCE

Standard	Service limit
0.1-0.7mm	1.1mm

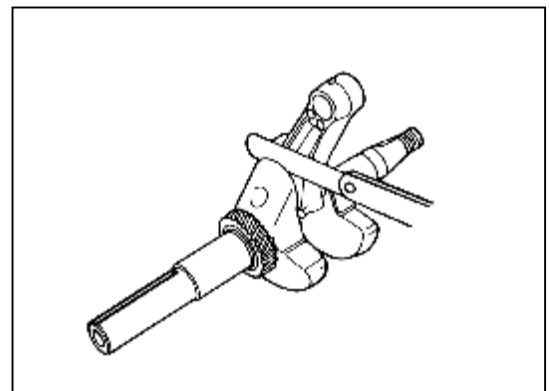

## 5) CONNECTING ROD BIG END OIL CLEARANCE (RADIAL)

- Clean all oil from crank pin surface.
  - Place a piece of plastigauge, install connecting rod, and tighten the bolts to the specified torque.  
Tightening torque: 12-14N.m
- Note: Do not rotate crankshaft when tightening the bolts.
- Remove the connecting rod and measure the plastigauge.
  - If the clearance exceeds the service limit, replace the connecting rod and recheck the clearance.

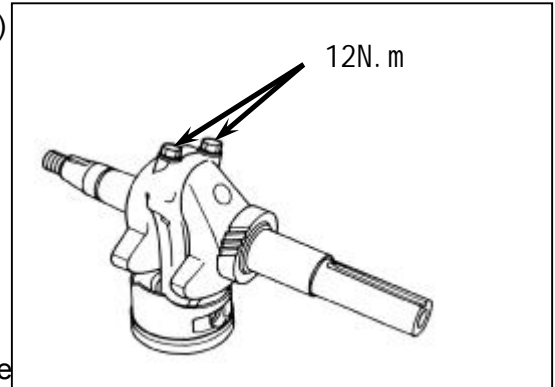

If clearance still exceeds service limit after using the new connecting rod, lap the crank pin to recondition it, and use a connecting rod smaller than the standard value.

Standard	Service limit
0.04-0.063 mm	0.12 mm

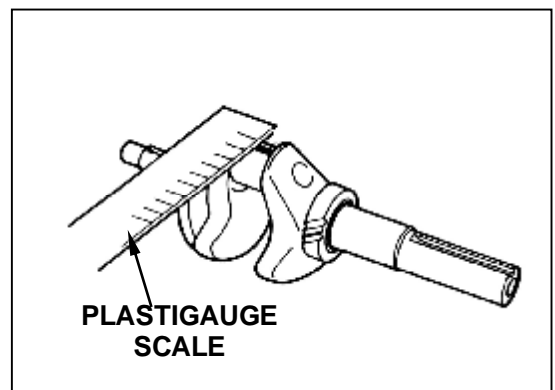

# SECTION 4. DISASSEMBLY AND SERVICE

## CAMSHAFT

As the main driving piece of the gasoline engine's valve actuating mechanism, the camshaft controls opening and closing of intake and exhaust valves following a regular rule. Check cam surface and cam height for damage, check whether camshaft and bearings have play or are worn, if so, replace all of them.

### 1) CAMSHAFT CAM HEIGHT

Standard	Service limit
20.54 mm	20.29 mm

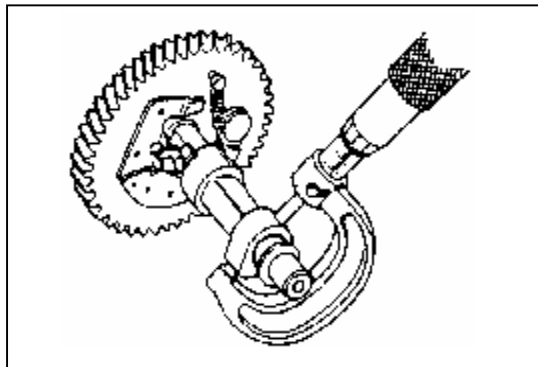

### 2) CAMSHAFT DIAMETER

Standard	Service limit
11.964 mm	11.896 mm

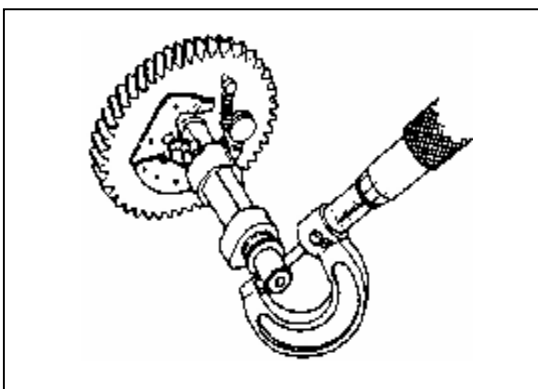

### 3) CAMSHAFT HOLDER ID

Standard	Service limit
12.0 mm	12.048 mm

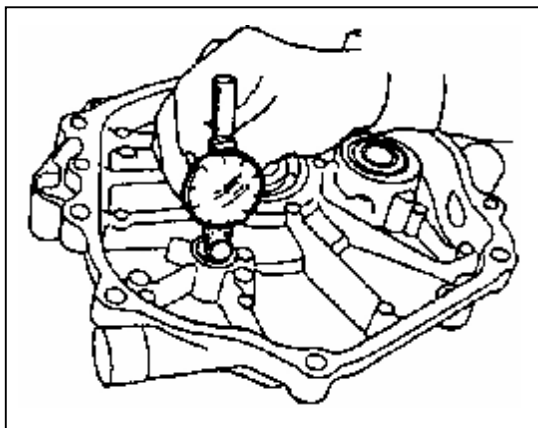

# SECTION 4. DISASSEMBLY AND SERVICE

## BEARING

Clean bearing in solvent and dry it.

Spin the bearing by hand and check for play. replace the bearing if it is noisy or has excessive play

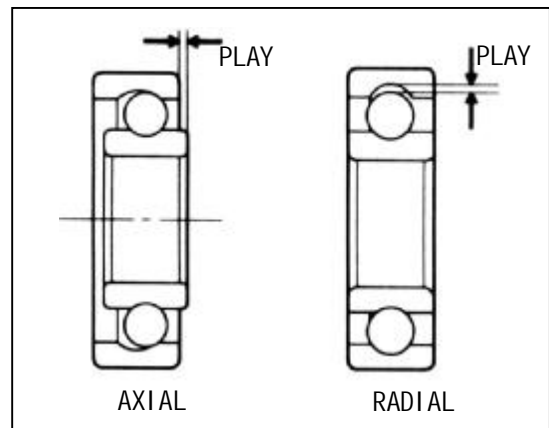

## OIL LEVEL SWITCH

Measure continuity of oil level switch with an ohmmeter.

If, when the crankcase has not enough oil or has no oil, oil level switch's black lead is conductive to ground wire, and when the crankcase has enough oil, oil level switch's black lead is not conductive to the ground wire, it is normal.

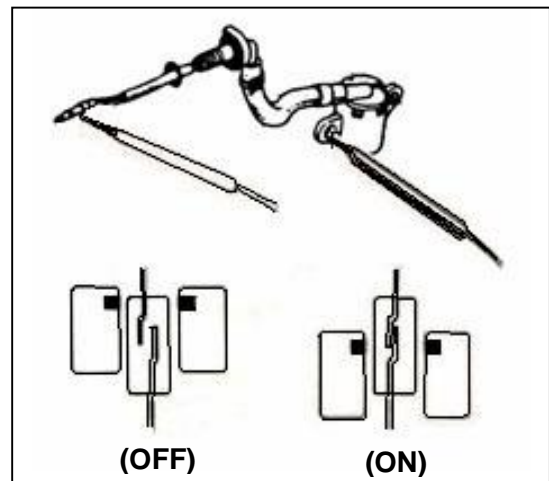

# SECTION 4. DISASSEMBLY AND SERVICE

## 4-4-2 Cylinder Head / Valves

### a. DISASSEMBLY/ REASSEMBLY

#### BREATHER TUBE

**REMOVAL/ INSTALLATION:**  
Connect one end to cylinder head cover, the other end to breather chamber cap's vertical-up vent.

#### CYLINDER HEAD

**REASSEMBLY:**  
Before installation, remove carbon deposits from the combustion chamber and inspect the valve seats' tightness. Measure the compression of the cylinder head after reassembly.

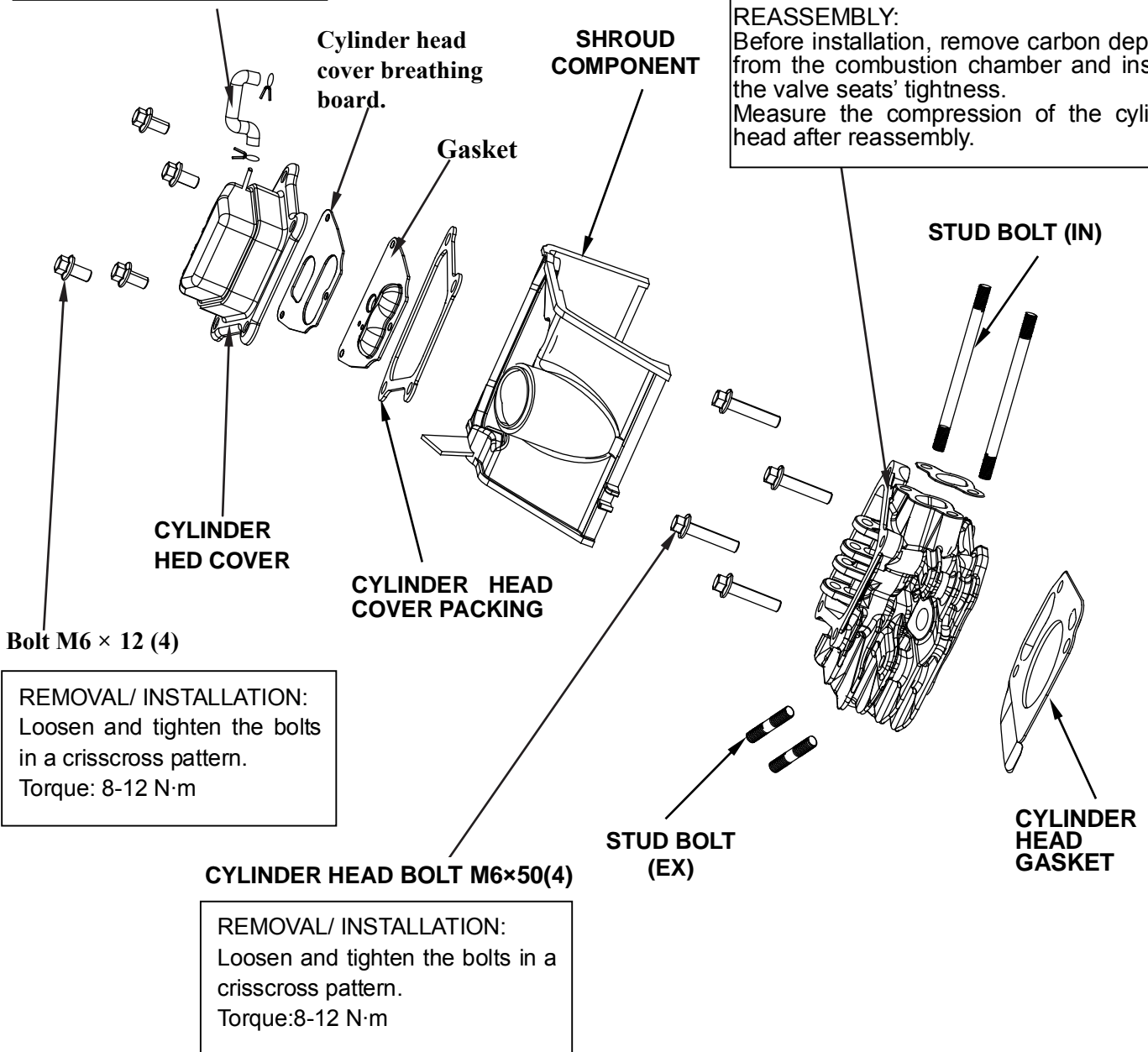

# SECTION 4. DISASSEMBLY AND SERVICE

## b. DISASSEMBLY/ REASSEMBLY

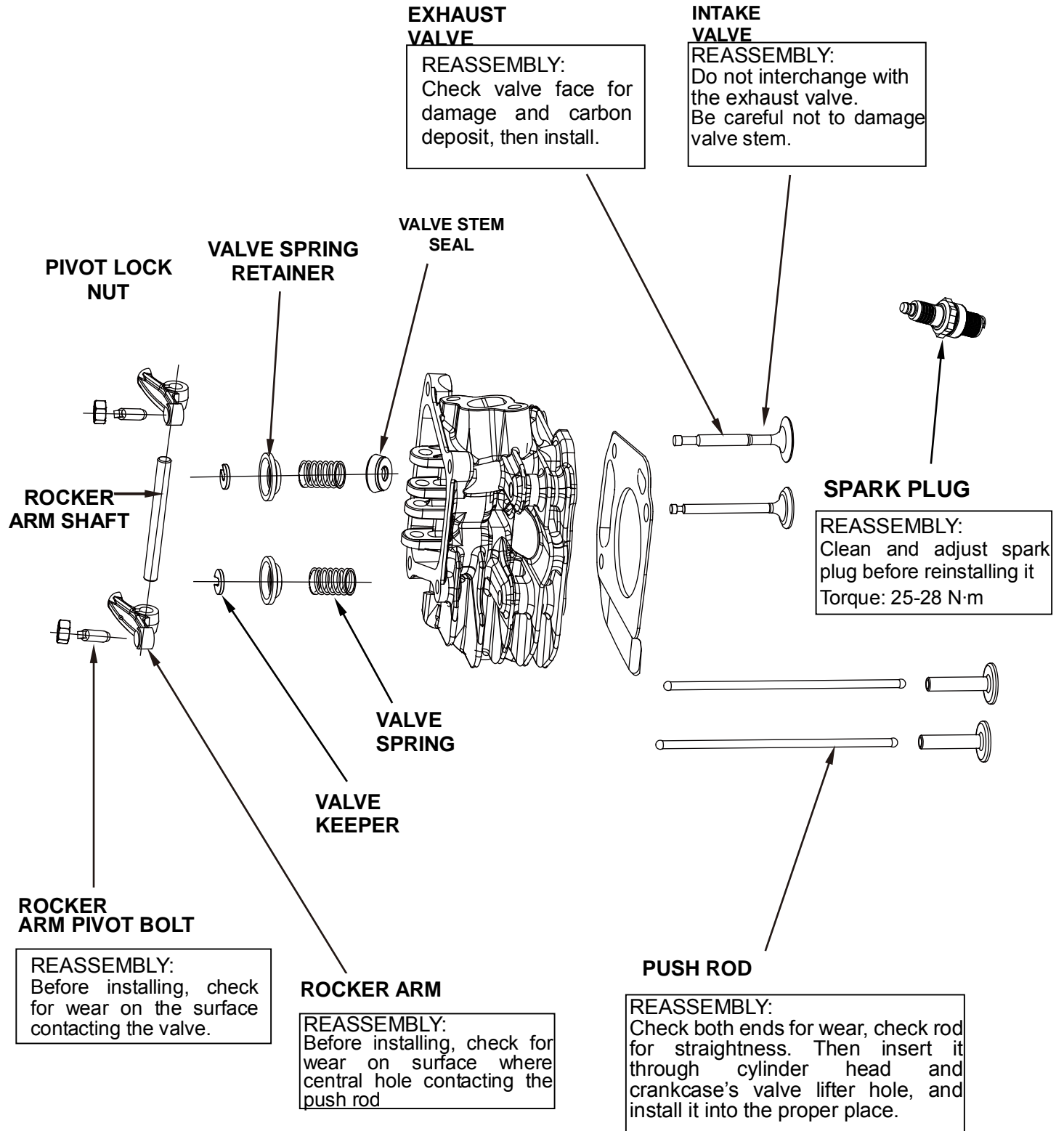

# SECTION 4. DISASSEMBLY AND SERVICE

## c.INSPECTION

### 1) VALVE STEM O.D.

Inspect each valve stem's outer diameter, if it is less than standard value or beyond service limit, or valve face has visible burns or cracks, replace it with a new one.

	Standard	Service limit
IN	4.968 mm	4.906 mm
EX	4.928 mm	4.763 mm

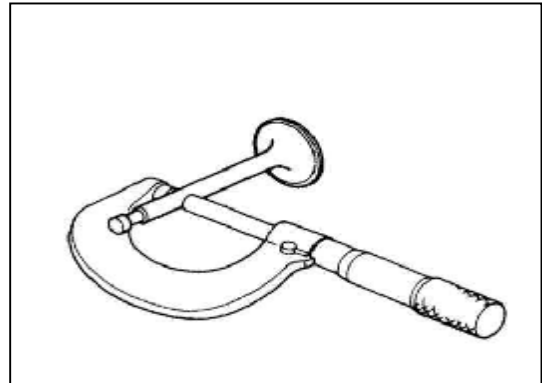

### 2) SPRING FREE LENGTH

Measure the free length of each valve spring, if it is less than standard value or beyond service limit, replace the spring.

Standard	Service limit
25 mm	23.5 mm

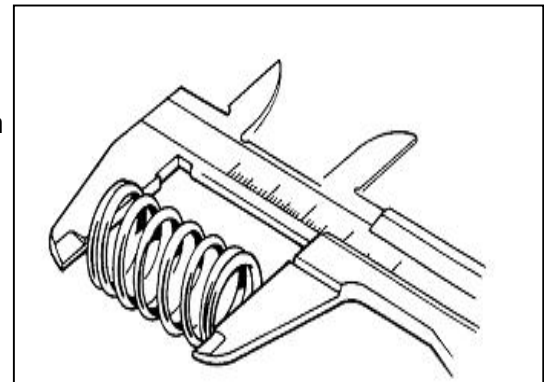

### 3) CYLINDER HEAD

Remove carbon deposits from the combustion chamber.

Clean off any gasket material from the cylinder head surface.

Check spark plug hole and valve areas, and valve guides for cracks.

Check the cylinder head for warpage with a straight edge and a feeler gauge.

Service limit	Replace if warpage exceeds 0.10 mm

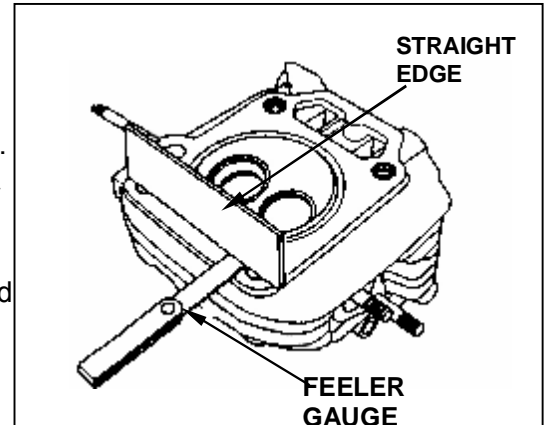

### 4) VALVE GUIDE

#### INSPECTION:

a) Check valve guide's inner surface for flatness, smoothness, scratches, and scores; check whether fit between valve guides and cylinder head is firm.

b) Ream the valve guides to remove any carbon deposits before

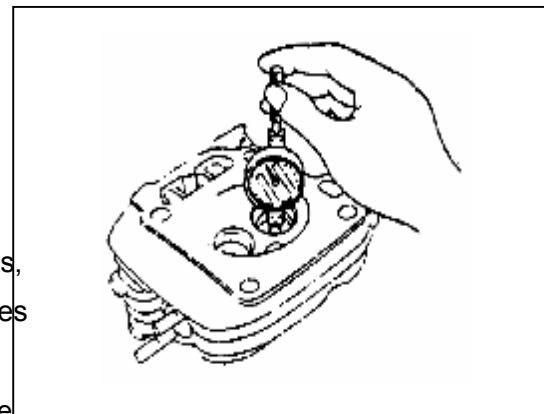

# SECTION 4. DISASSEMBLY AND SERVICE

measuring.

Replace valve guides if their inner diameters are smaller than standard value or beyond service limit.

Standard	Service limit
5 mm	5.072 mm

Replace:

a) Put replacement valve guides in a refrigerator's freezing chamber to freeze it for about 1 hour.

b) Use a valve guide driver to remove valve guides from the combustion chamber side.

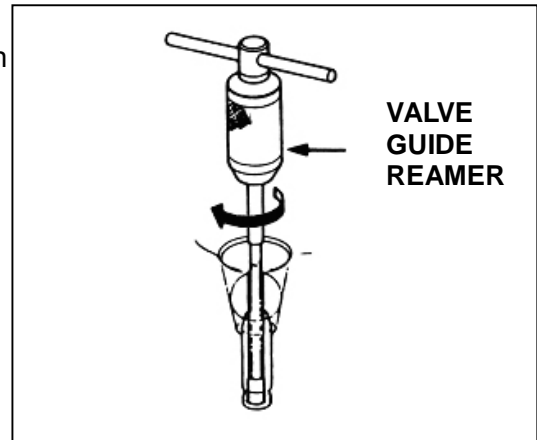

## NOTICE

Be careful not to damage cylinder head when removing valve guides

c) install new guides from cylinder head's valve spring side.

Exhaust valve side: Drive exhaust valve guide until the clip fully contacts cylinder head.

Intake valve side: Drive intake valve guide until it reaches specified height (measured from guide top to cylinder head surface.)

d) After installing, check valve guide for damage, if so, it must be replace.

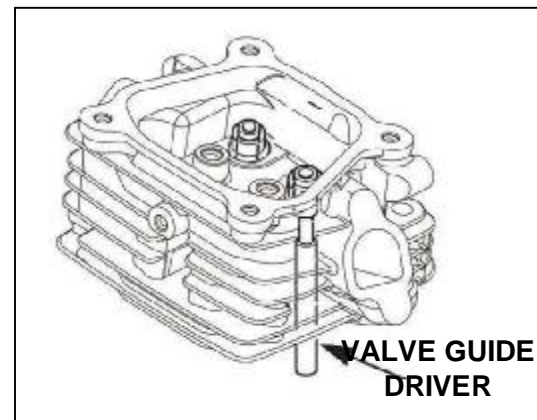

Ream:

For best results, be sure the cylinder head is at room before reaming valve guides.

a) Coat the reamer and valve guide with cutting oil. Rotate the reamer clockwise through the valve guide for the full length of the reamer. Continue to rotate the reamer clockwise while removing it from the valve guide.

Tools: Valve guide reamer

b) Thoroughly clean the cylinder head to remove cutting residue and other dirty matters.

c) Check the valve guide bore, it should be straight, unobstructed, round and centered in the valve guide, insert the valve and check operation. If the valve does not operate smoothly, the guide may have been bent during installation. Replace the valve guide if it is bent or damaged.

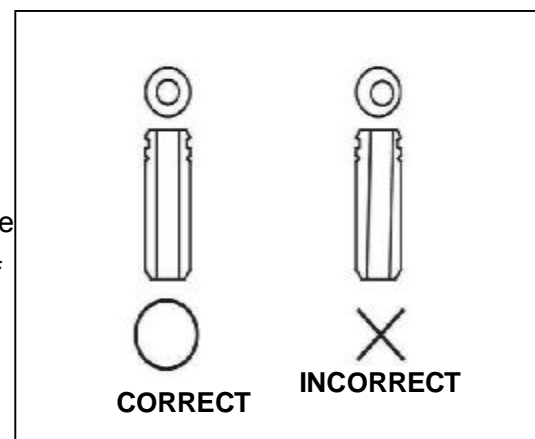

# SECTION 4. DISASSEMBLY AND SERVICE

- d) Check the valve stem-to-guide clearance.
- e) Valve stem-to-guide clearance: Deduct the valve stem outside diameter from the valve guide bore's inside diameter to get the clearance between the valve guide and valve stem.
- f) If the clearance is over the service limit, judge whether a new guide can make the clearance within service limit, if it can, replace the guide and ream the guide, recondition the valve seat when replacing the valve guide.

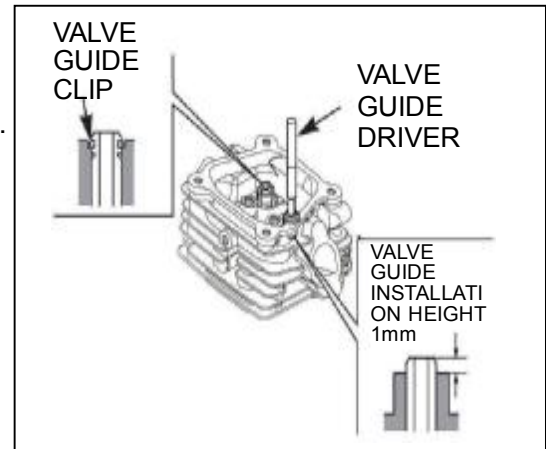

## 5) VALVE SEAT:

- a) Thoroughly clean the combustion chamber and valve seats to remove carbon deposits. Apply a light coat of red lead powder or erasable color painting to the valve faces.
- b) Insert the valves, and then press the valve several times forcefully. Be sure the valve does not rotate on the seat. The transferred marking compound will show any area of the seat that is not concentric with the valve.

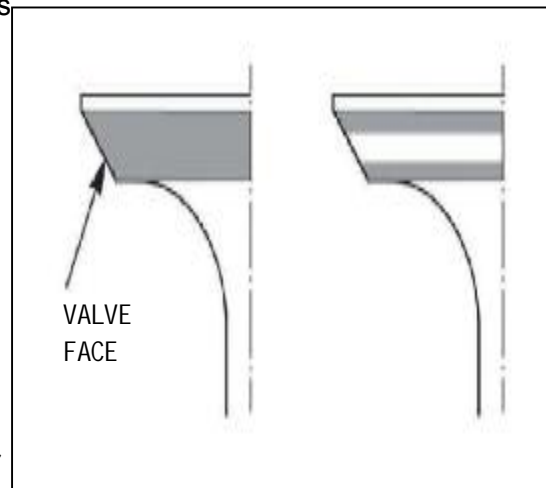

- c) Using a 45° cutter, remove enough material to produce a smooth and concentric seat. Turn the cutter clockwise, never counterclockwise. Continue to turn the cutter as you lift it from the valve seat.

Tool: Valve seat cutter

- d) Use the 32°-45° cutters to narrow and adjust the valve seat so that it contacts the middle of the valve face.

The 32° cutter removes material from the top edge (contact too high).

The 45° cutter removes material from the bottom edge (contact too low). Be sure that the width of the finished valve seat is within specification.

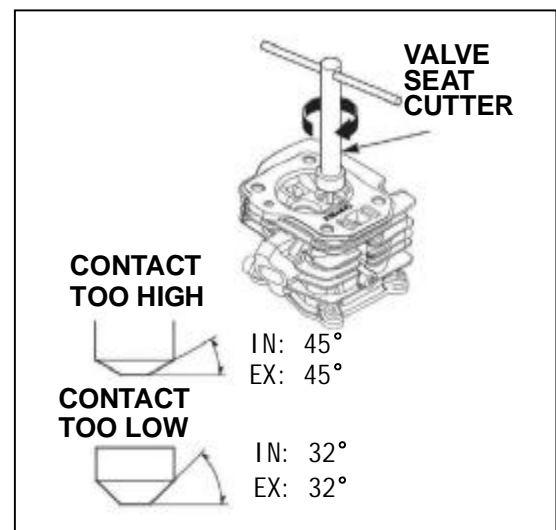

Standard	Service limit
0.8 mm	2.0 mm

## SECTION 4. DISASSEMBLY AND SERVICE

---

e) Make a light pass with the 45° cutter to remove any possible burrs at the edges of the seat.

f) After resurfacing seats, inspect for even valve seating. width Apply colorant to the valve's tapered face, insert the valve and press it forcefully several times, be sure the valve does not rotate on the seat. The seating surface, as shown by the transferred marking compound, should have good contact all the way around.

g) Apply the lapping compound to the valve seat face, and rotate valve lapper to recondition the valve seat.

h) After reassembling, check the valve clearance.

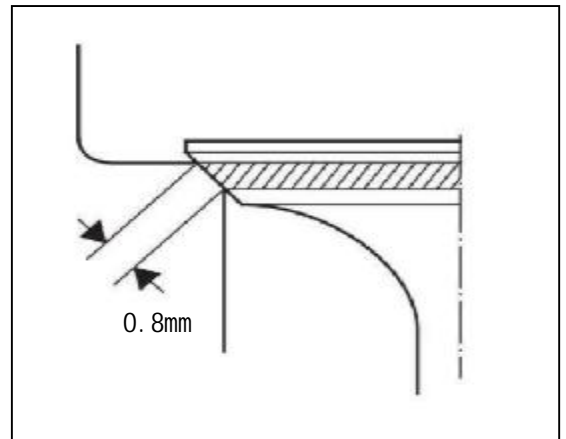
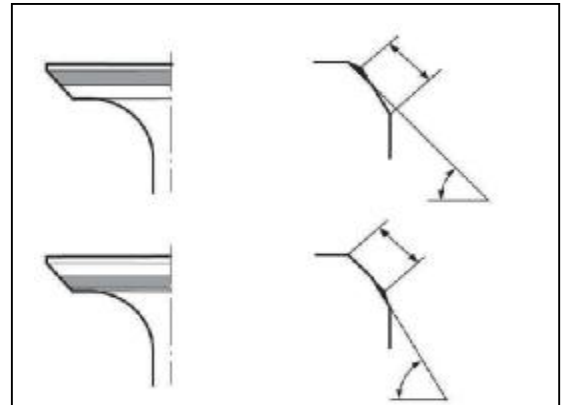

# SECTION 4. DISASSEMBLY AND SERVICE

## 4-4-3 Flywheel / Ignition Coil/Recoil Starter

### a. DISASSEMBLY/ REASSEMBLY

#### IGNITION COIL

DISASSEMBLY/ REASSEMBLY:  
Check for cracked or damaged insulation before installation, to avoid electric leakage

#### Flywheel

DISASSEMBLY:  
Use a special tool (flywheel puller) to remove. Never knock with a hammer.

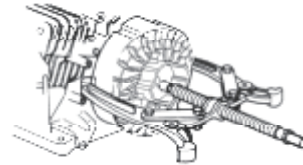

REASSEMBLY:  
Remove oil or any other dirty matter from crankshaft and flywheel's tapered surface before installation.

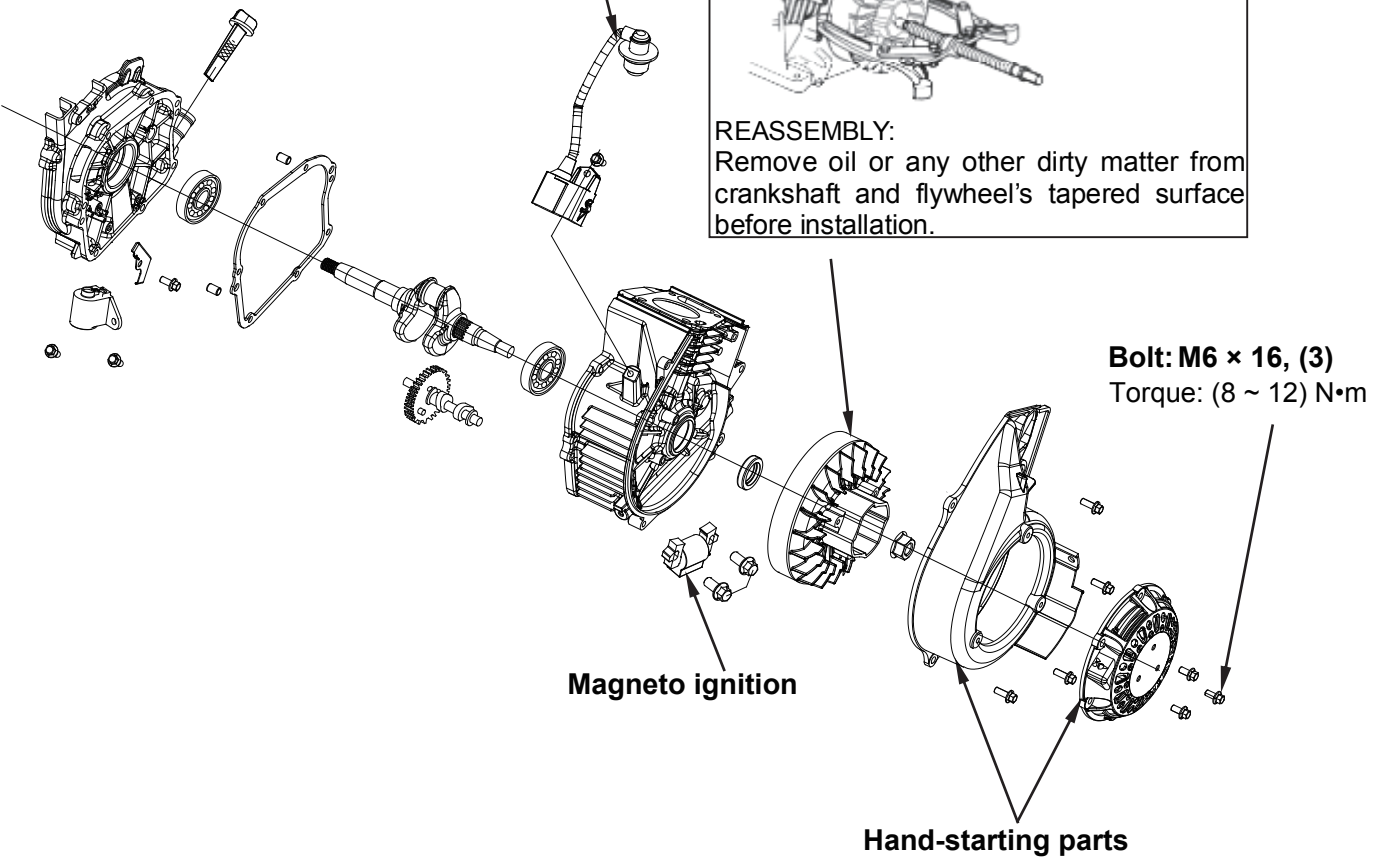

Assembly:  
Remove the soil and grass attached around these parts prior to assembly and note the assembly direction.

# SECTION 4. DISASSEMBLY AND SERVICE

---

## b.INSPECTION

### CHARGE COIL, IGNITION COIL

Attach one ohmmeter lead to charge coil's black lead while touching the other tester to the iron core. Measured resistance value should be  $0\Omega$ .

Attach one ohmmeter lead to charge coil's red/white lead while touching the other tester to the iron core. Measured resistance value should be  $16 \pm 5\Omega$ .

Attach one ohmmeter lead to charge coil's brown lead while touching the other tester to the iron core. Measured resistance value should be  $380 \pm 50\Omega$ .

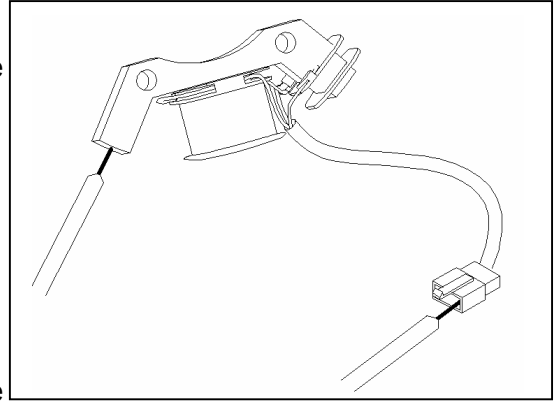

If the measured resistance value doesn't meet the specification, replace the charge coil.

**If the charge coil passes inspection but spark still cannot be produced, replace the ignition coil.**

# SECTION 4. DISASSEMBLY AND SERVICE

## c. DISASSEMBLY/ REASSEMBLY (STARTER ASSY)

**WARNING** The recoil starter can cause personal injury, Wear safety glasses. Do not let the recoil spring snap out.

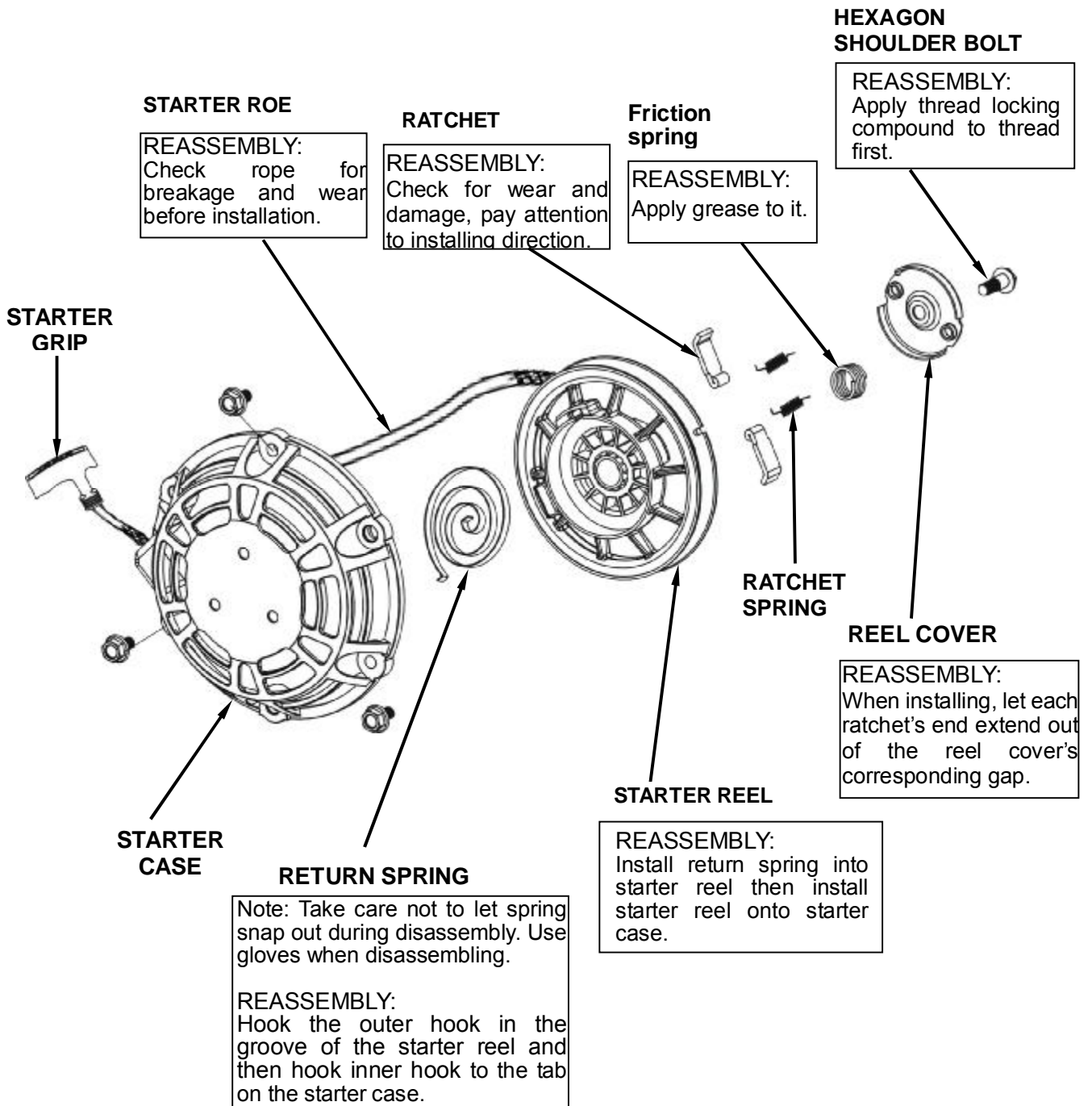

# SECTION 4. DISASSEMBLY AND SERVICE

## ASSEMBLY OF RECOIL STARTER

**⚠ WARNING** Wear gloves and safety glasses to protect your hands and eyes.

**⚠ WARNING** Don't let return spring snap out.

1) Put return spring into spring cover, hook spring's outer hook firmly to the cover's gap and align with starter reel's groove, then install cover into starter reel. Apply grease to starter case's tab. Install the starter reel and turn the starter reel counterclockwise to hook the spring inner hook to the tab on the starter case.

2) Make a knot at one end of the rope, then pull the other end a bit out of starter reel's rope hole. Then turn starter reel 5 turns counterclockwise. Pull out the rope end from starter case hole and make a figure eight knot at the rope end.

3) Install ratchets, ratchet springs, reel cover and tighten reel cover bolt.

4) Check the operation of the ratchet by pulling the starter rope several times.

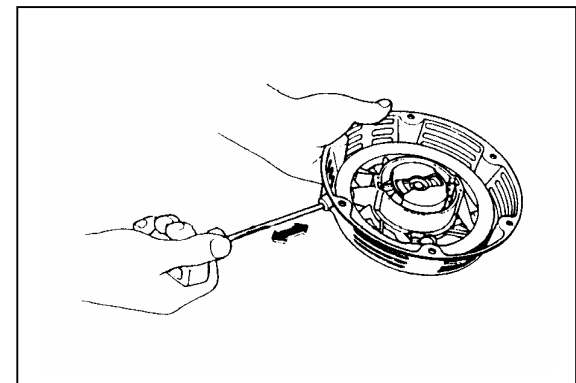
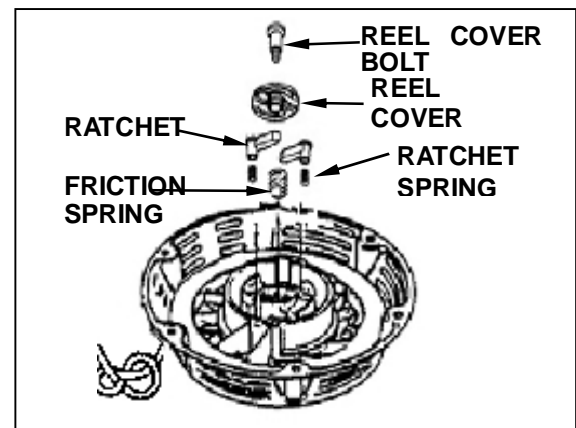
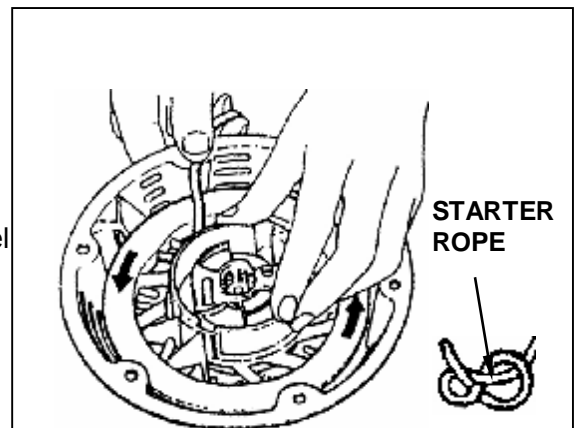
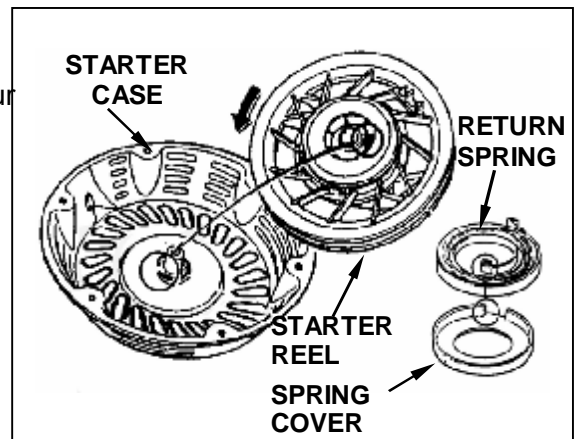

# SECTION 4. DISASSEMBLY AND SERVICE

## 4-4-4 Carburetor

### a. DISASSEMBLY/ REASSEMBLY

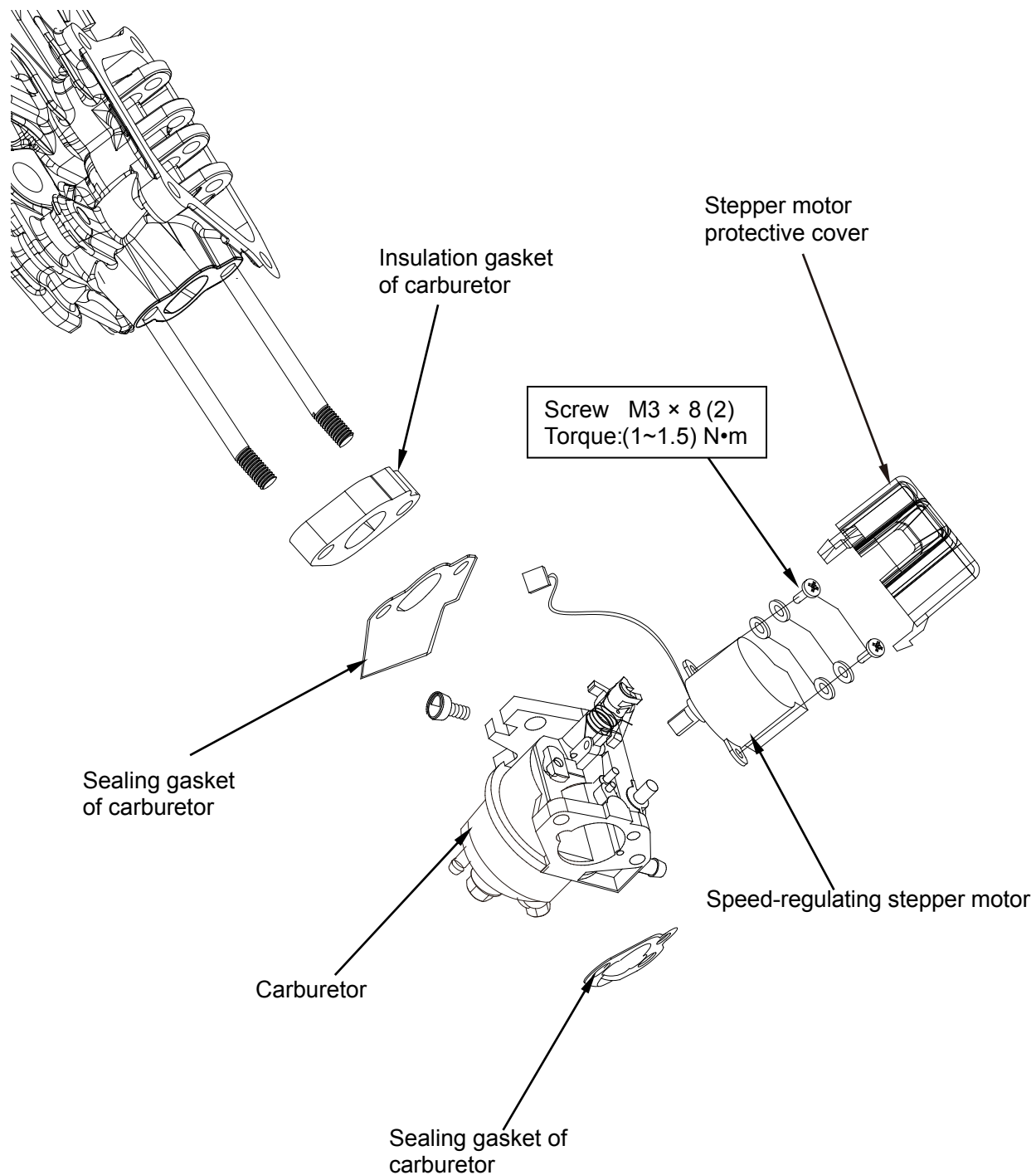

# SECTION 4. DISASSEMBLY AND SERVICE

## b. DISASSEMBLY/ REASSEMBLY

**WARNING** Gasoline is flammable and explosive. Close the fuel shut off valve, and drain the carburetor before servicing the carburetor. Smoking and fire are prohibited.

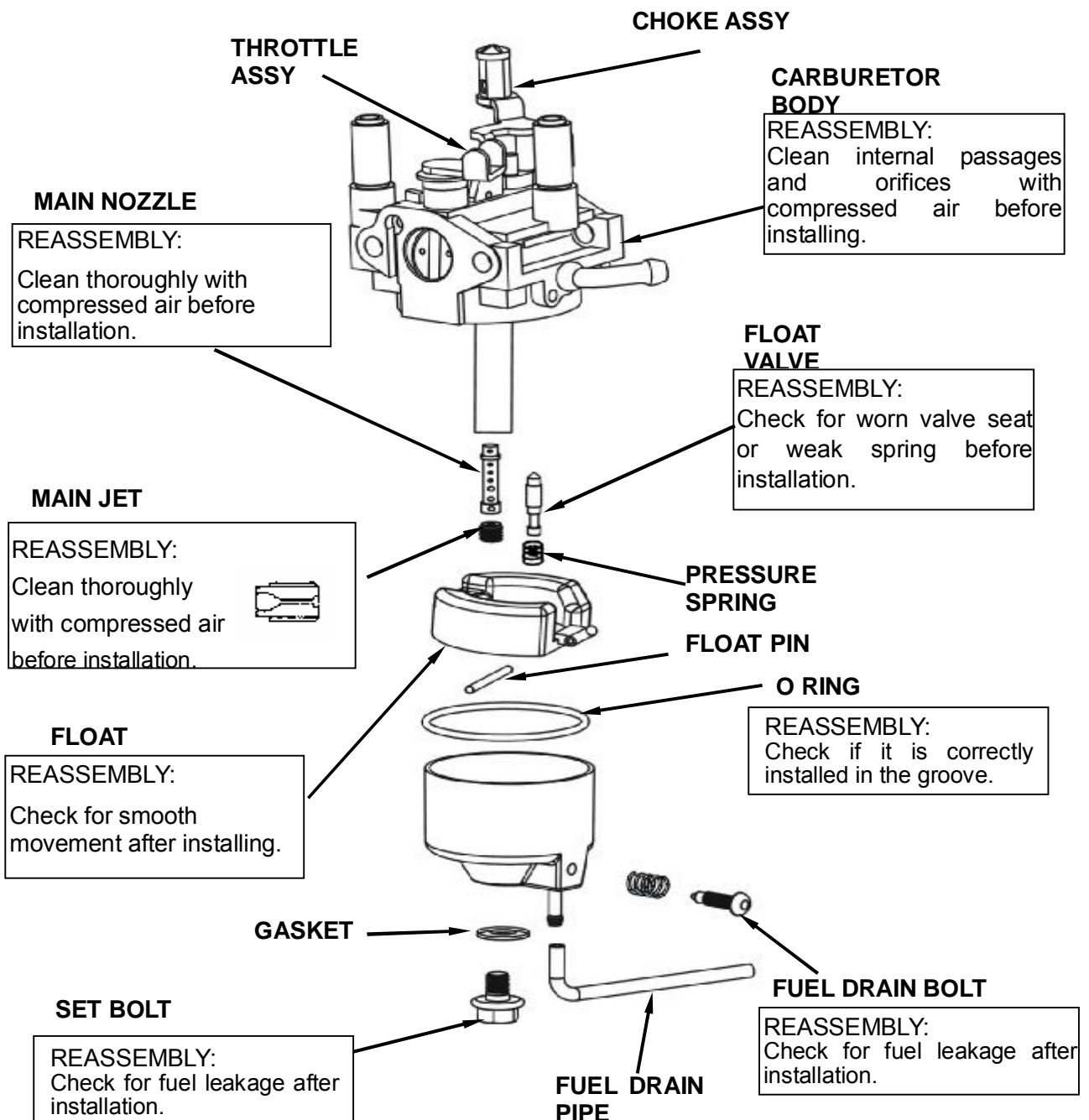

## SECTION 4. DISASSEMBLY AND SERVICE

---

### c.INSPECTION

#### SPEED VARIABLE STEPPER MOTOR

Measure resistance between ends of stepper motor socket 2's diagonal, resistance value should be  $50\pm 1\Omega$ , if it is exceeded, replace the stepper motor.

Rotate stepper motor's central shaft when the motor's power is on, the shaft should not be stuck or has play, if so, replace the motor.

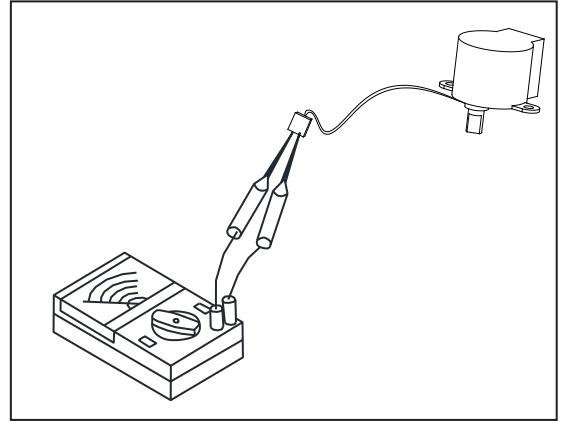

# SECTION 4. DISASSEMBLY AND SERVICE

---

## 4-5 Generator

### 4-5-1 Fuel Tank

#### DISASSEMBLY/ REASSEMBLY

**⚠ WARNING** Gasoline is flammable and explosive, drain the carburetor and fuel tube before disassembly, spilled fuel must be wiped off immediately.

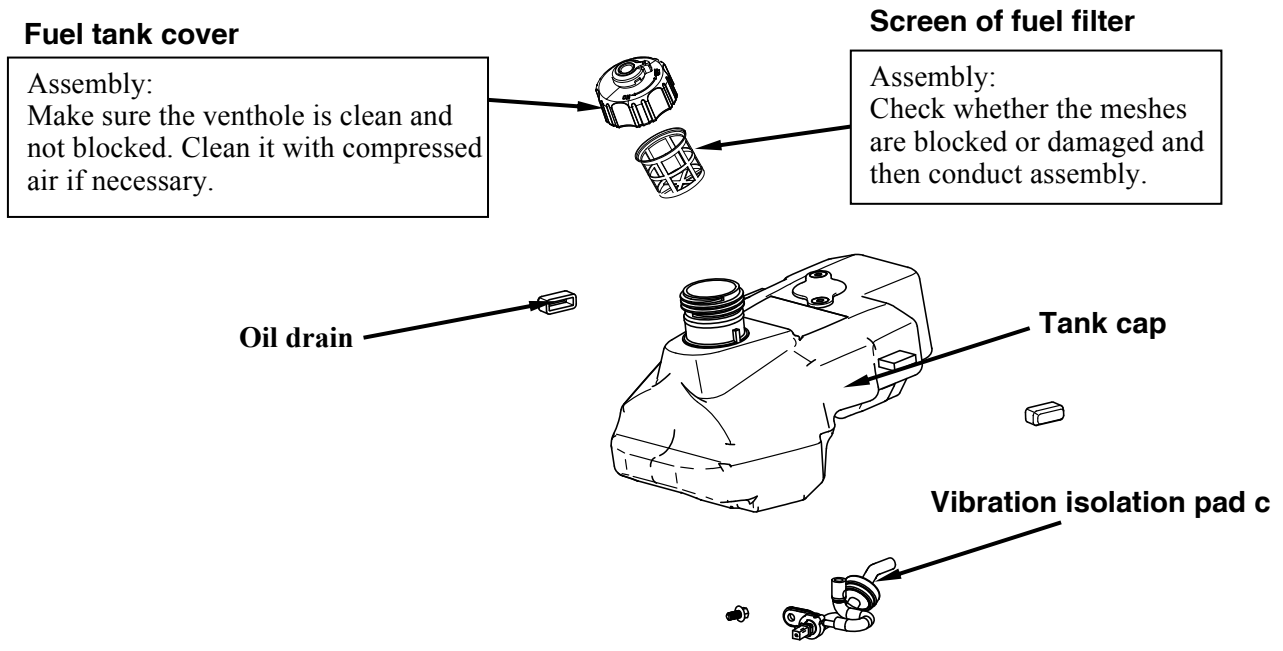

# SECTION 4. DISASSEMBLY AND SERVICE

## 4-5-2 Muffler

### DISASSEMBLY/ REASSEMBLY

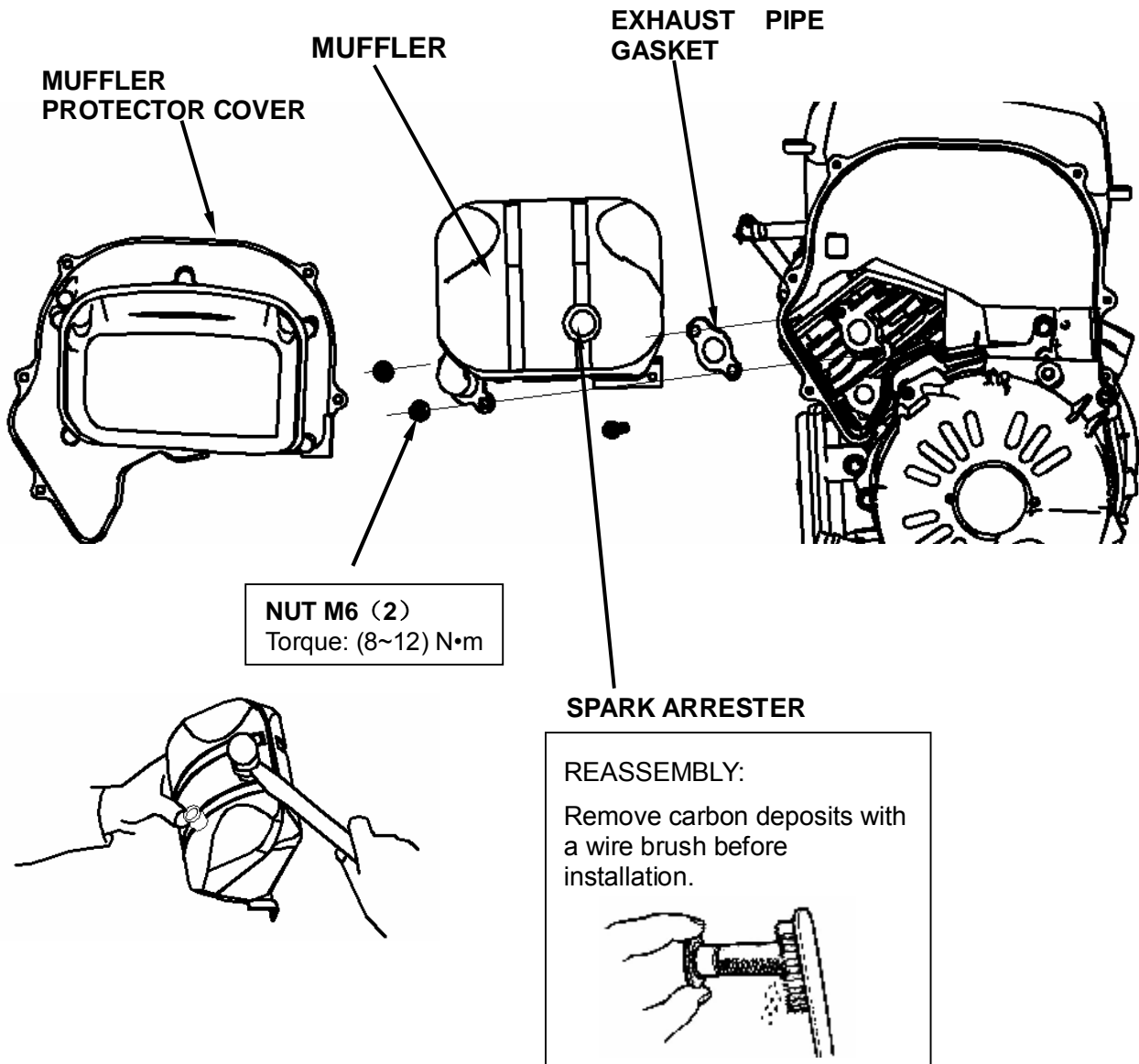

#### REASSEMBLY:

Install after removing the carbon deposits from the muffler using a plastic hammer.

# SECTION 4. DISASSEMBLY AND SERVICE

---

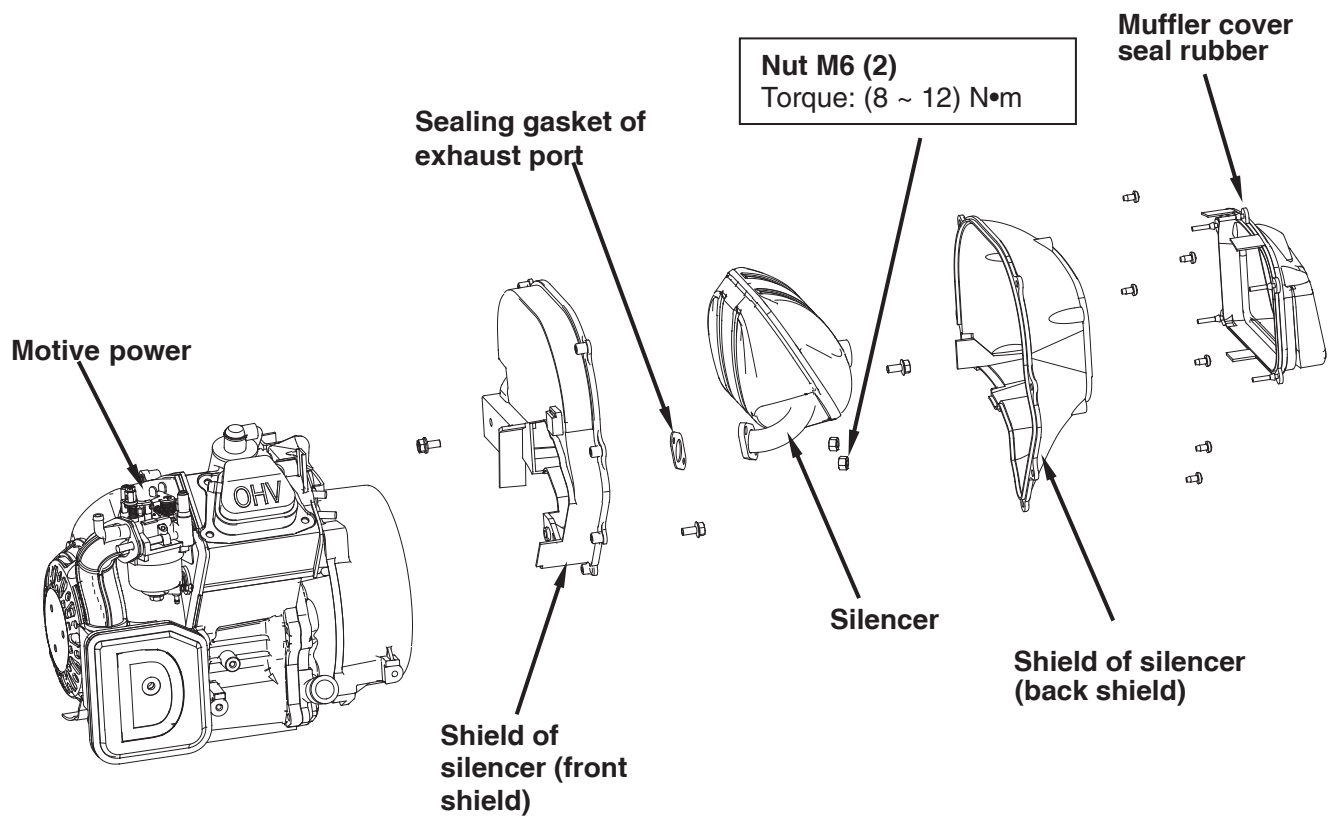

# SECTION 4. DISASSEMBLY AND SERVICE

## 4-5-3 Frame/Bedplate Combination DISASSEMBLY/ REASSEMBLY

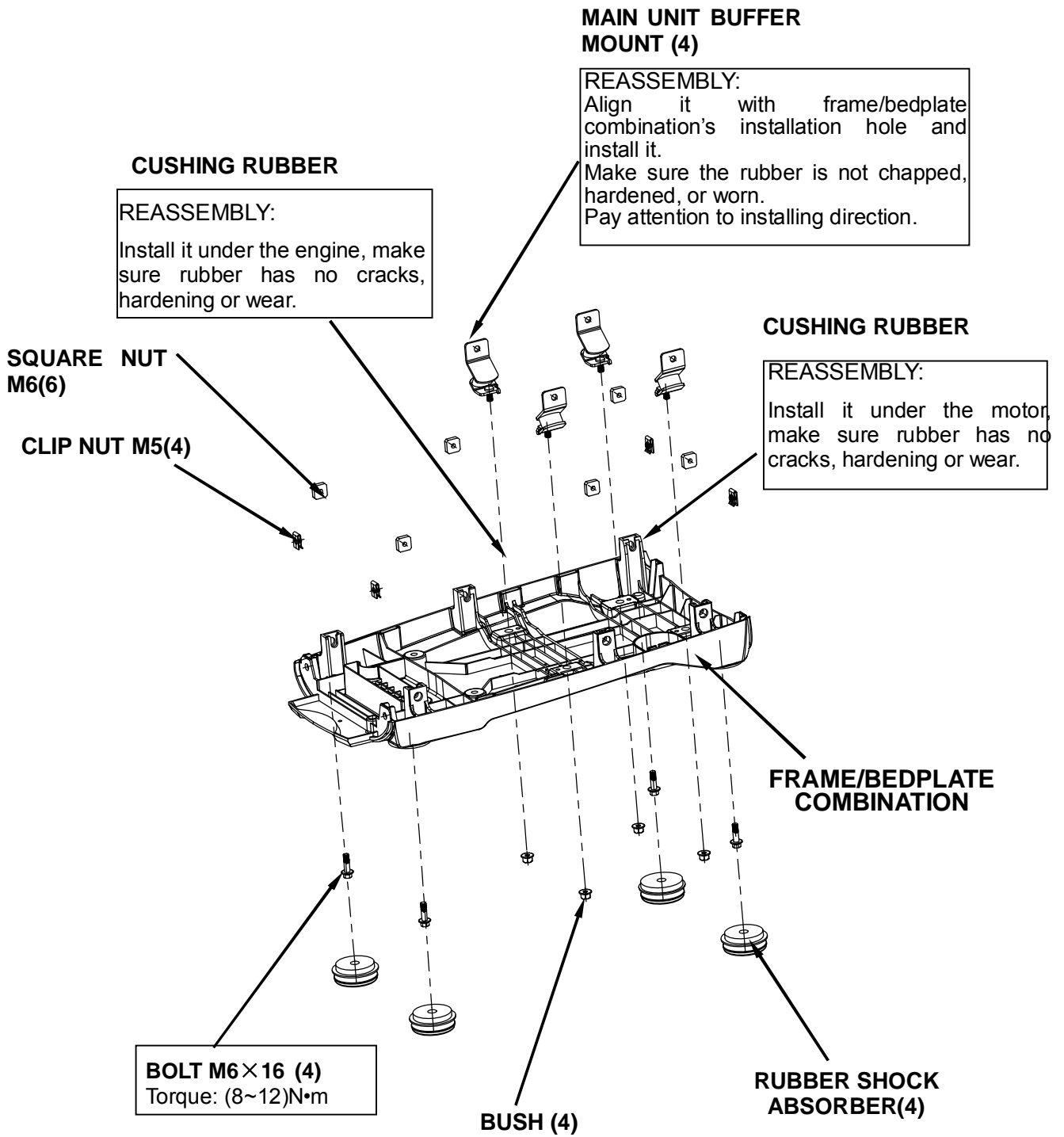

# SECTION 4. DISASSEMBLY AND SERVICE

## 4-5-4 Motor

### a. DISASSEMBLY/ REASSEMBLY

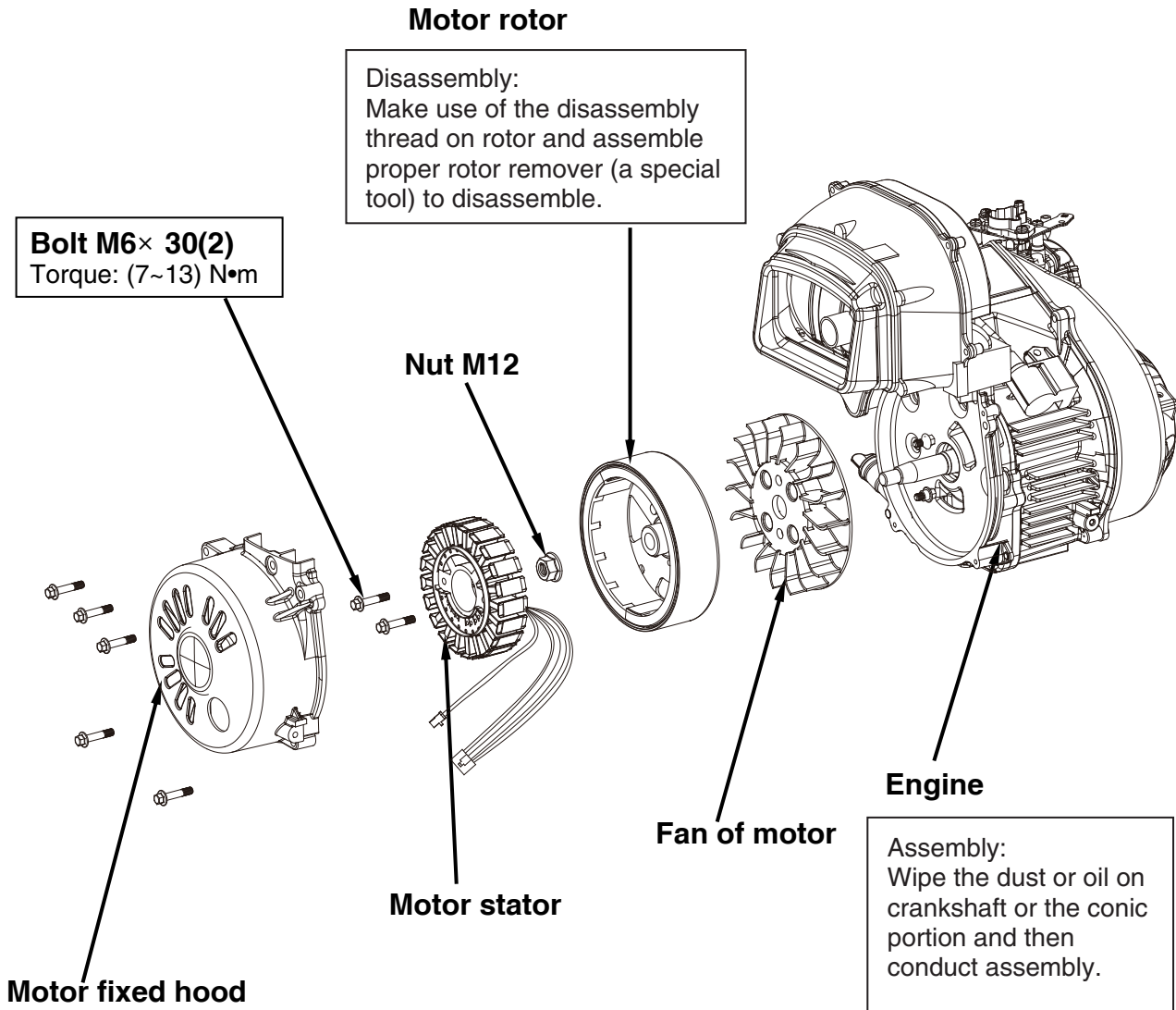

# SECTION 4. DISASSEMBLY AND SERVICE

## b. INSPECTION

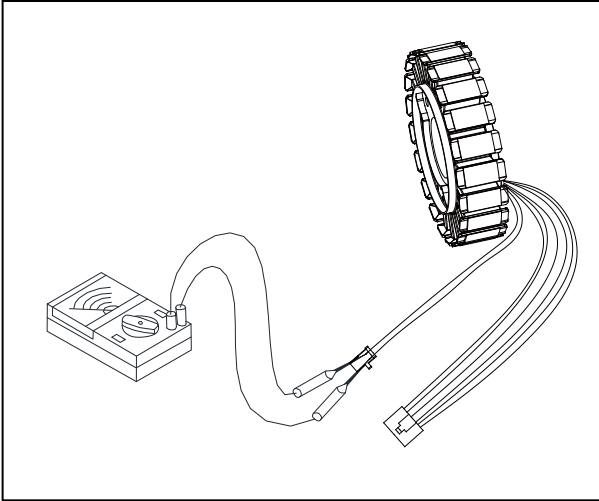

### Main winding/ Secondary winding

If no AC voltage is output, check whether AC receptacle is damaged, if so, replace the receptacle.

Check whether there's voltage between motor stator windings, if there is, replace the inverter; if not, replace the stator.

Table of resistance between windings rated :

P2200i (INVERTER) 230V 1.9kW

P2500i (IRONSIDE) 230V 2.0kW

Part	Wire color	Resistance
Main winding	Red	4.26Ω±0.34Ω
Secondary winding	White	0.43Ω±0.04Ω
DC winding	Blue	0.113Ω±0.01Ω

If resistance is zero or infinite, replace the stator.

Remove the stator from the motor.

Check whether insulation of stator windings'enameled wires and leads' insulation are obviously damage, if so, replace the stator.

Note: Be careful not to damage insulation of windings' enameled wires and leads' insulationl when removing and installing the stator.

# SECTION 4. DISASSEMBLY AND SERVICE

---

## 4-5-5 Inverter

### a. DISASSEMBLY/ REASSEMBLY

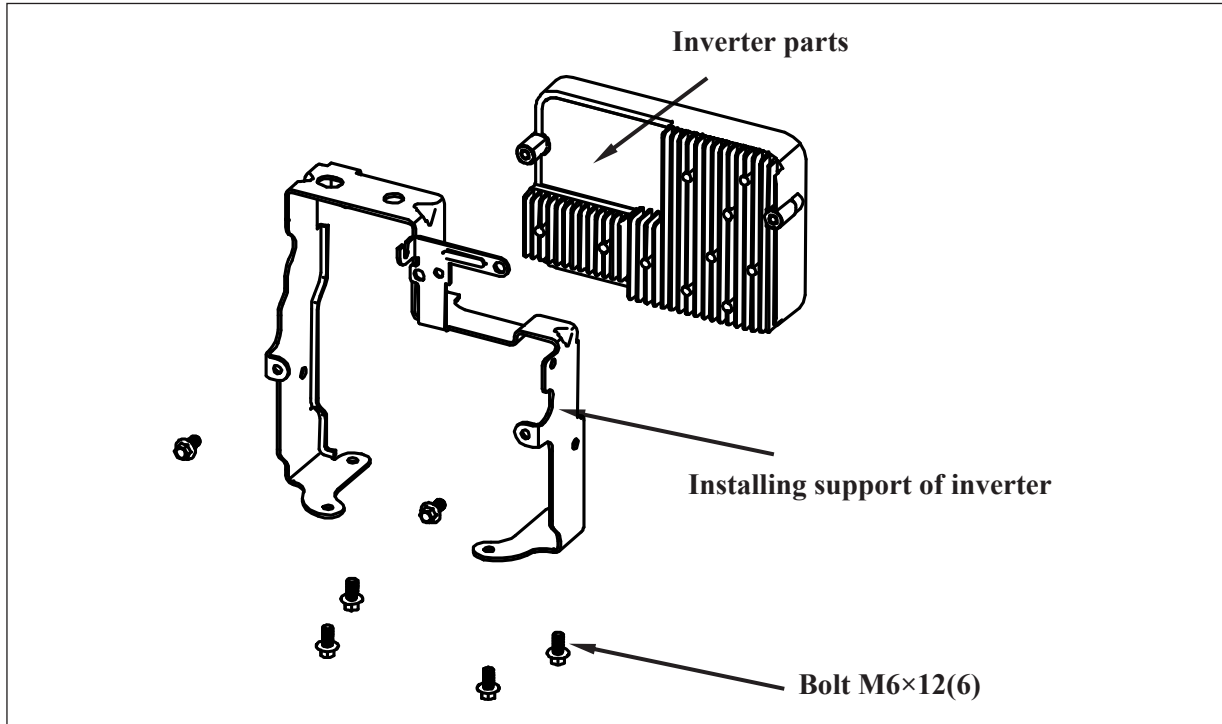

# SECTION 4. DISASSEMBLY AND SERVICE

## Inverter

Check whether colors of inverter's leads have changed, whether inverter's packing resin has bulging blisters, check whether all the inverter's electric parts, connectors, and connecting wires have visible color change or damage.

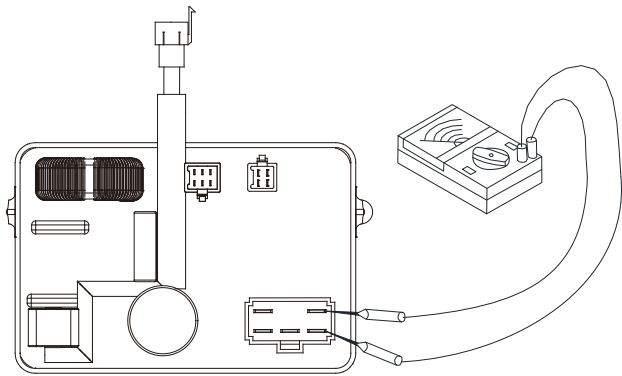

Input shorted (low voltage): When the red lights are on, the speed of the generator is out of control. If the resistance is zero, please replace the inverter.

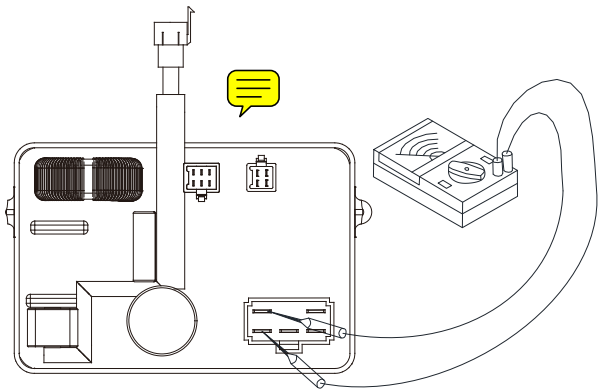

Input shorted (three phase): The red light is always on, the green light is off and the resistance becomes stronger at the same time, and the generator cannot be started; the resistance level is tested for the three-phase connector (each resistance between every two connectors needs to be tested). If the resistance is zero, please replace the inverter.

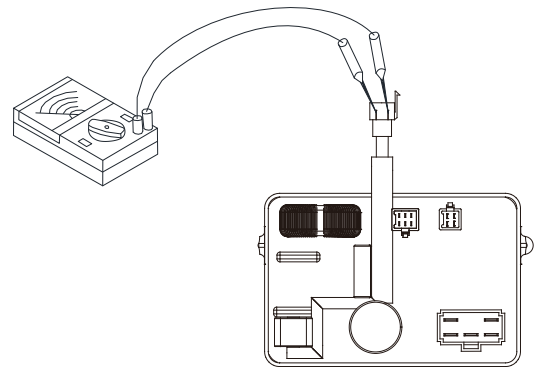

Output shorted: When the green light is off and the red light is on, the resistance level determines the output terminal. If the resistance is zero, replace the inverter.

## Inching switch

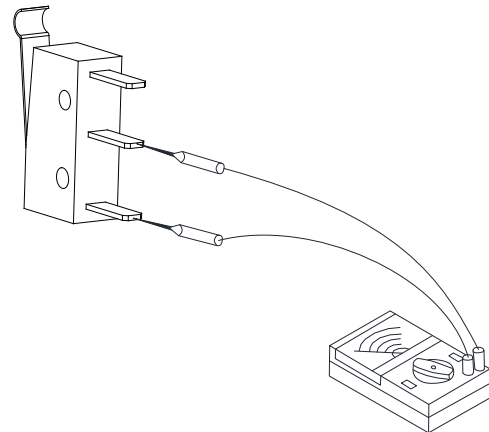

With spring leaves apart, use the ohmmeter scale to measure resistance between two output terminals. If measured resistance value is zero, replace the inching switch.

With spring leaves compressed firmly, use ohmmeter scale to measure resistance between two output terminals. If measured resistance value is infinite, replace the inching switch.

# SECTION 4. DISASSEMBLY AND SERVICE

## 4-5-6 Control Panel

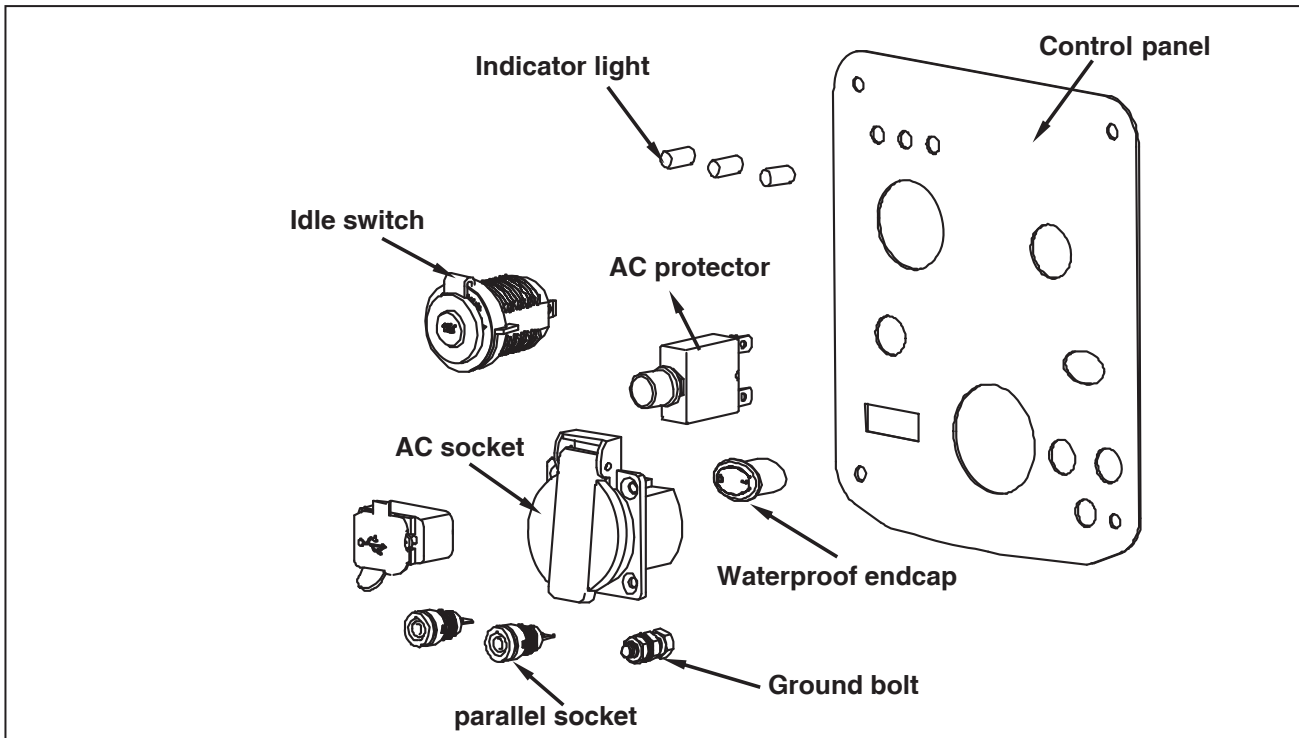

### a. DISASSEMBLY/ REASSEMBLY

#### INSPECTION

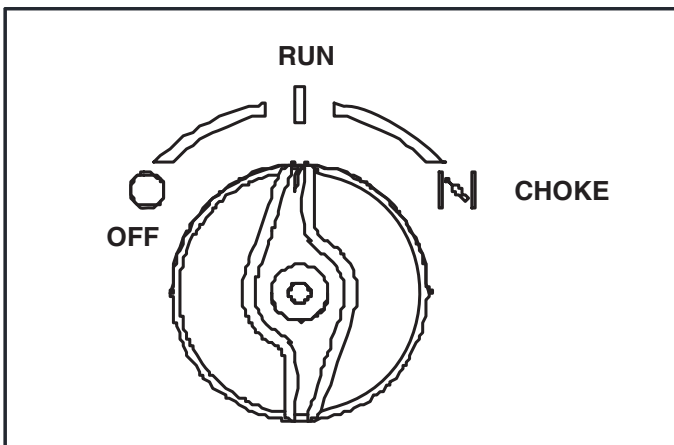

#### Combination switch

Check state of ignition circuit, fuel cock and choke with combination switch in different positions.

When combination switch is in  "OFF" position, ignition circuit is close, which means inching switch's two output terminals are made, ignition lead is earthed; fuel cock is shut off, the engine cannot run.

When combination switch is in  "RUN" position, ignition circuit is in working state, which means inching switch's two output terminals are broken; fuel cock is open, the choke is fully open, the engine can run normally.

When combination switch is in  "CHOKE" position, ignition circuit is in working state, which means inching switch's two output terminals are broken; fuel cock is open, the choke is closed.

Check continuity between switch terminals with switch in different positions.

# SECTION 4. DISASSEMBLY AND SERVICE

## Wire harness

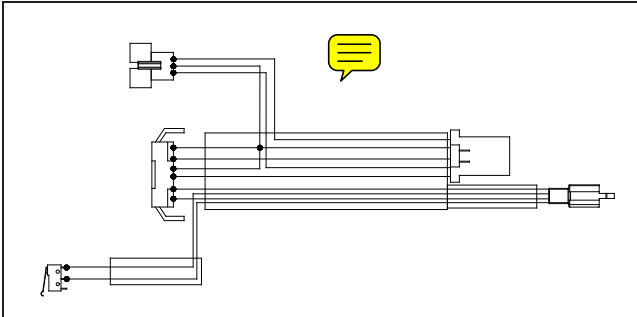

Detach wire harness from panel and inverter. Check wire insulation for apparent damage. If it is damaged, replace the harness.

Use an ohmmeter to check and confirm each wire's continuity. If resistance value is infinite, replace the harness.

Note: Use a clamp to remove and assembly the harness, use a suitable force to avoid wires and wire connectors.

## Oil warning light (red)

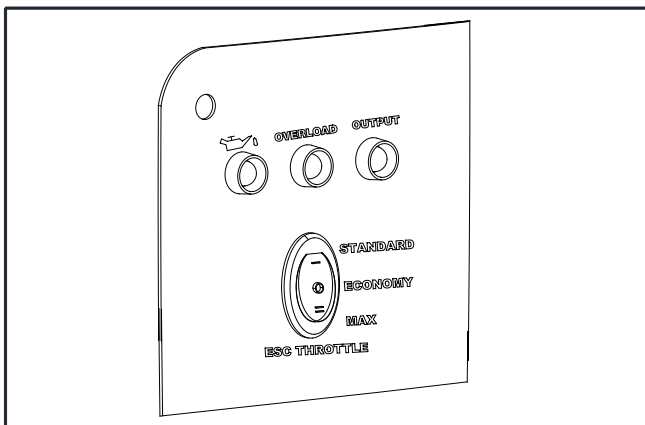

When oil in crankcase falls below safe level, oil

alert system will automatically shut the engine, and oil warning light goes on; the engine cannot be started until oil is added to reach the required level.

**Note:** If the engine stalls or cannot be started, turn power switch into "ON" position, then pull starter grip.

If oil warning light continues flashing for some seconds, oil is insufficient. Add oil and restart.

Use an ohmmeter to check the light and to confirm continuity, if resistance value is infinite, replace the light.

## Overload light (red)

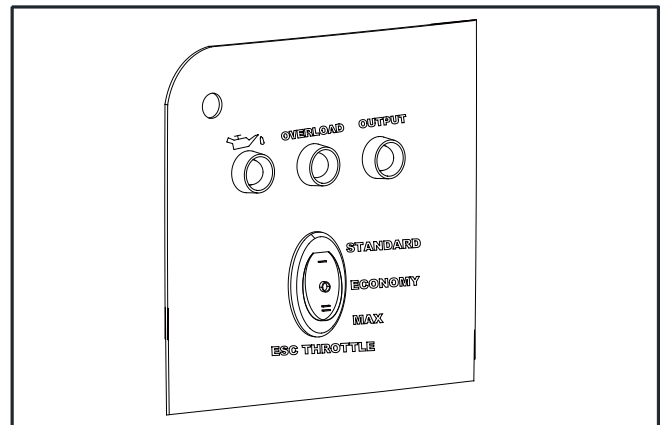

Overload light getting on means the engine detects the overload on connected electrical equipment's output that causes overheating of inverter, or a higher AC voltage. At such point, AC protector acts to stop the generator's work, and to protect the generator and electric equipment connected to it. AC indicator light (green) goes out, and overload light (red) gets on, but the engine will not stop running.

When overload light goes on and the genset has no output, please take the following measures:

1. Shut all electric equipment connected, stop the

# SECTION 4. DISASSEMBLY AND SERVICE

engine.

2. Lower total power of all connected electrical equipment into the range of rated output.
3. Check cooling air intake port for obstruction by foreign matters, and whether relevant control parts are abnormal, if so, solve the problem immediately.
4. Restart the engine after checking.

**Note:** When using electric equipment with high starting current (like compressors, submersible pumps, etc.), the overload light might be on for some seconds immediately after starting, but it doesn't indicate any fault mentioned above.

Use an ohmmeter to check the light and to confirm continuity, if resistance value is infinite, replace the light.

### AC indicator light (green)

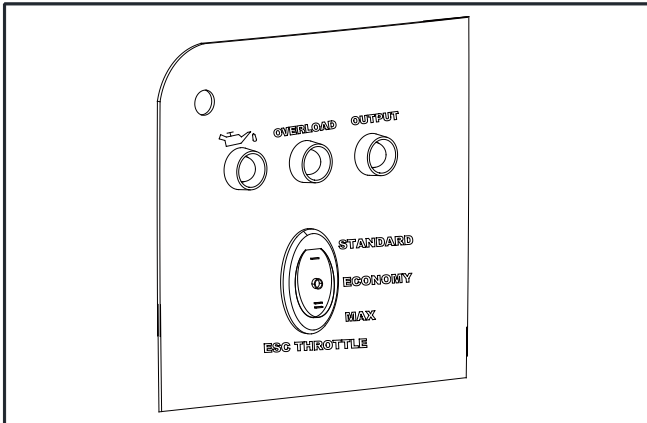

When engine is started and has normal output, AC indicator light turns on.

Use an ohmmeter to check the light and to confirm continuity, if resistance value is infinite, replace the light.

### Power down switch

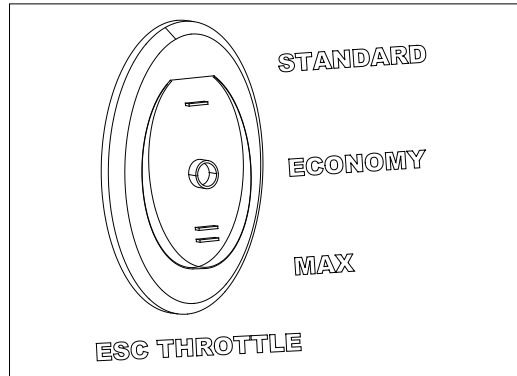

#### ① "STANDARD"

When the ECO switch is placed in the "STANDARD" position, it will run at 4100rpm .

#### ② "ECONOMY"

When the ECO switch is placed in the "ECONOMY" position, the engine speed will be controlled according to the connected load to obtain better fuel consumption and low noise .

#### ③ "MAX"

When the ECO switch is placed in the "MAX" position, it will run at 5000rpm .

Tip: when using following devices, such as air compressor and sinking water pump, ESC must be closed as relatively large starting current is required.

# SECTION 4. DISASSEMBLY AND SERVICE

## 4-5-7 Outer case assembly

### a. DISASSEMBLY/ REASSEMBLY

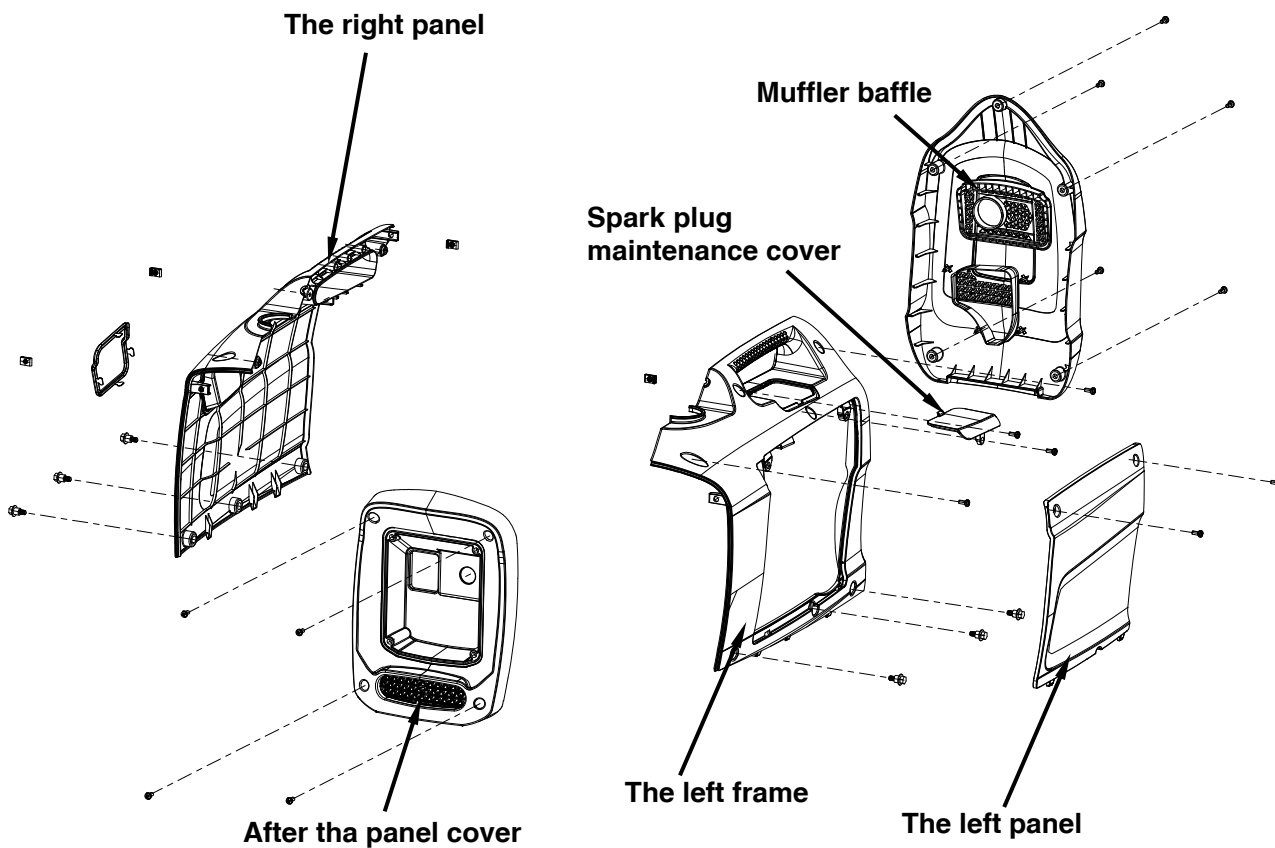

# SECTION 5 WIRING DIAGRAMS

